

# Lecture 23: Common Emitter Amplifier Frequency Response. Miller's Theorem.

We'll use the high frequency model for the BJT we developed in the previous lecture and **compute the frequency response** of a common emitter amplifier, as shown below in Fig. 5.71a.

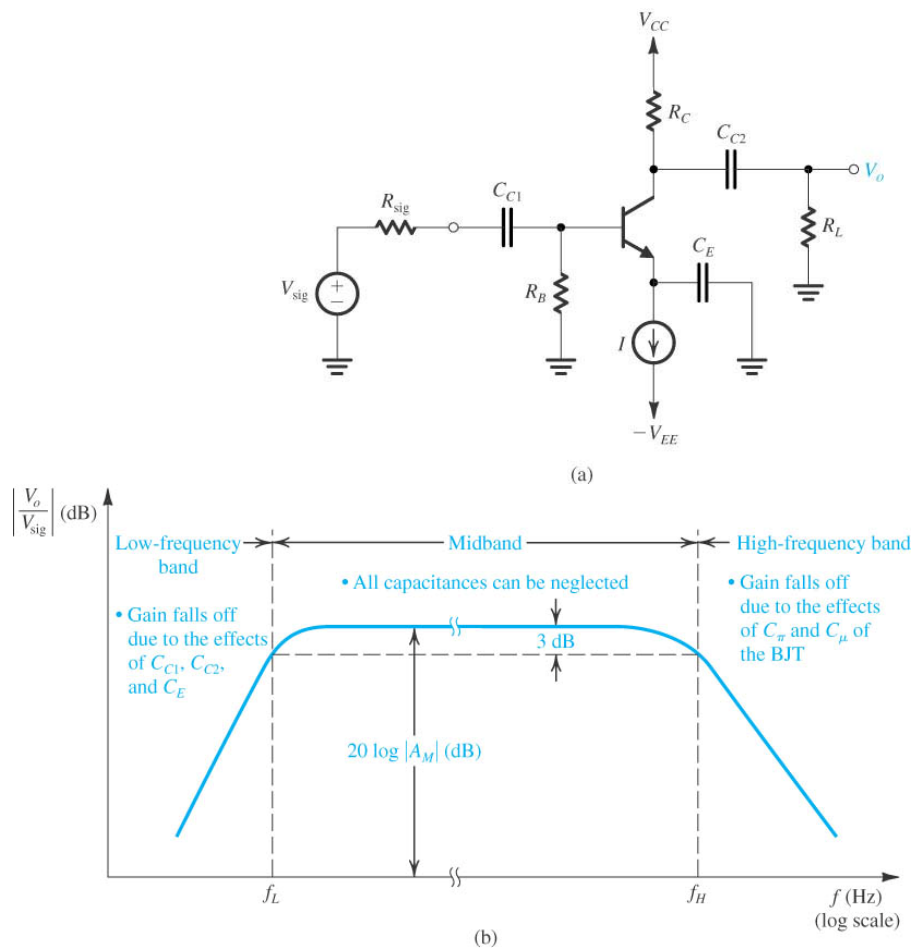

(Fig. 5.71)

As we discussed in the previous lecture, there are three distinct region of frequency operation for this – and most – transistor amplifier circuits. We'll examine the operation of this CE

amplifier more closely when operated in three frequency regimes.

## Mid-band Frequency Response of the CE Amplifier

At the mid-band frequencies, the DC blocking capacitors are assumed to have very small impedances so they can be replaced by short circuits, while the impedances of  $C_\pi$  and  $C_\mu$  are very large so they can be replaced by open circuits. The equivalent small-signal model for the mid-band frequency response is then

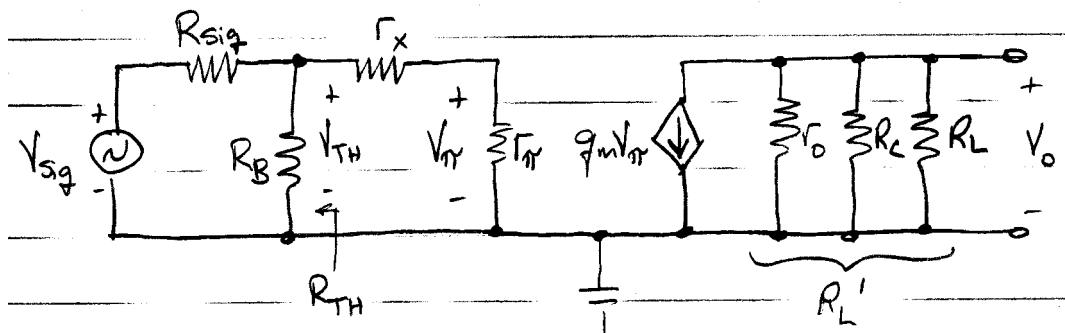

We'll define

$$R_L' = r_o \parallel R_C \parallel R_L \quad (1)$$

so that at the output

$$V_o = -g_m R_L' V_\pi \quad (2)$$

Using Thévenin's theorem followed by voltage division at the input we find

$$V_{\pi} = \frac{r_{\pi}}{r_{\pi} + r_x + R_{TH}} V_{TH} = \frac{r_{\pi}}{r_{\pi} + r_x + R_B \parallel R_{sig}} \cdot \frac{R_B}{R_B + R_{sig}} V_{sig} \quad (3)$$

Substituting (3) into (2) we find the mid-band voltage gain  $A_m$  to be

$$A_m \equiv \frac{V_o}{V_{sig}} = \frac{-g_m r_{\pi}}{r_{\pi} + r_x + R_B \parallel R_{sig}} \cdot \frac{R_B}{R_B + R_{sig}} \cdot (r_o \parallel R_C \parallel R_L) \quad (4)$$

## High Frequency Response of the CE Amplifier

For the high frequency response of the CE amplifier of Fig. 5.71a, the impedance of the blocking capacitors is still negligibly small, but **now the internal capacitances of the BJT are no longer effectively open circuits.**

Using the high frequency small-signal model of the BJT discussed in the previous lecture, the equivalent small-signal circuit of the CE amplifier now becomes:

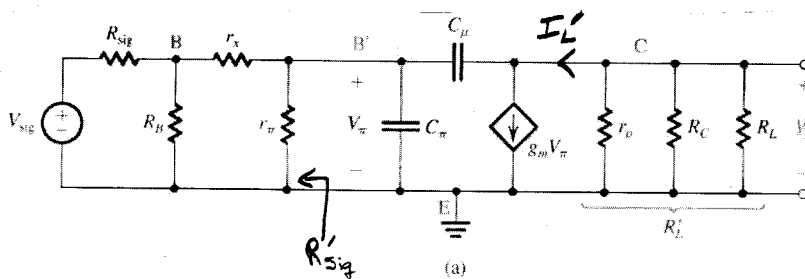

(Fig. 5.72a)

We'll simplify this circuit a little by calculating a Thévenin equivalent circuit at the input and using the definition for  $R_L'$  in (1):

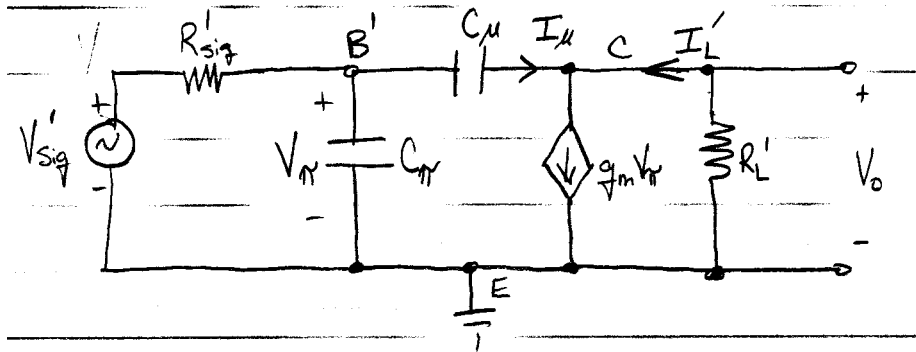

(Fig. 5.72b)

where it can be easily shown that  $V_{sig}'$  is  $V_{\pi}$  given in (3)

$$V_{sig}' = \frac{r_{\pi}}{r_{\pi} + r_x + R_B \parallel R_{sig}} \cdot \frac{R_B}{R_B + R_{sig}} V_{sig} \quad (5.167), (5)$$

while

$$R_{sig}' = r_{\pi} \parallel \left[ r_x + (R_B \parallel R_{sig}) \right] \quad (5.168), (6)$$

## Miller's Theorem

We can analyze the circuit in Fig. 5.72b through traditional methods, but if we apply **Miller's theorem** we can greatly simplify the effort. Plus, it will be easier to apply an approximation that will arise if we use Miller's theorem.

You may have seen Miller's theorem previously in circuit analysis. It is another **equivalent circuit theorem** for linear

circuits akin to Thévenin's and Norton's theorems. Miller's theorem applies to this circuit topology:

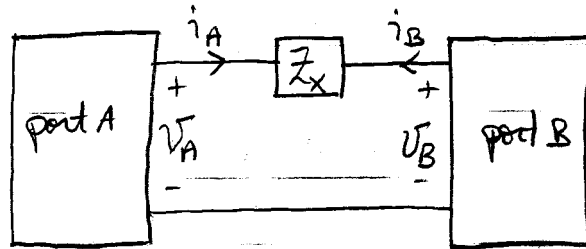

(Fig. 1)

The equivalent Miller's theorem circuit is

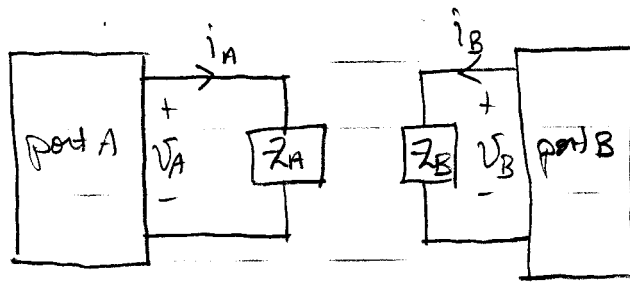

(Fig. 2)

where

$$Z_A = \frac{Z_x}{1 - \frac{v_B}{v_A}} \quad \text{and} \quad Z_B = \frac{Z_x}{1 - \frac{v_A}{v_B}} \quad (7),(8)$$

The equivalence of these two circuits can be **easily verified**. For example, using KVL in Fig. 1

$$v_A = i_A Z_x + v_B$$

or

$$i_A = \frac{v_A - v_B}{Z_x} \quad (9)$$

while using KVL in the left-hand figure of Fig. 2 gives

$$i_A = \frac{v_A}{Z_A} \quad (10)$$

Now, for the left-hand figure to be equivalent to the circuit in Fig. 1, then  $i_A$  in (9) and  $i_A$  in (10) must be equal. Therefore,

$$\frac{v_A - v_B}{Z_x} = \frac{v_A}{Z_A}$$

The equivalent impedance  $Z_A$  can be obtained from this equation as

$$Z_A = \frac{Z_x v_A}{v_A - v_B} = \frac{Z_x}{1 - \frac{v_B}{v_A}}$$

which is the same as (7). A similar result verifies (8).

So, for a resistive element  $R_x$ , Miller's theorem states that

$$R_A = \frac{R_x}{1 - \frac{v_B}{v_A}} \quad \text{and} \quad R_B = \frac{R_x}{1 - \frac{v_A}{v_B}} \quad (12),(13)$$

while for a **capacitive element**  $C_x$ , Miller's theorem states that

$$C_A = C_x \left( 1 - \frac{v_B}{v_A} \right) \quad \text{and} \quad C_B = C_x \left( 1 - \frac{v_A}{v_B} \right) \quad (14),(15)$$

---

## High Frequency Response of the CE Amplifier (cont.)

Returning now to the CE amplifier equivalent small-signal circuit of Fig. 5.72b, we'll **apply Miller's theorem** of Figs. 1 and 2 to this circuit and the **capacitor  $C_\mu$**  to give

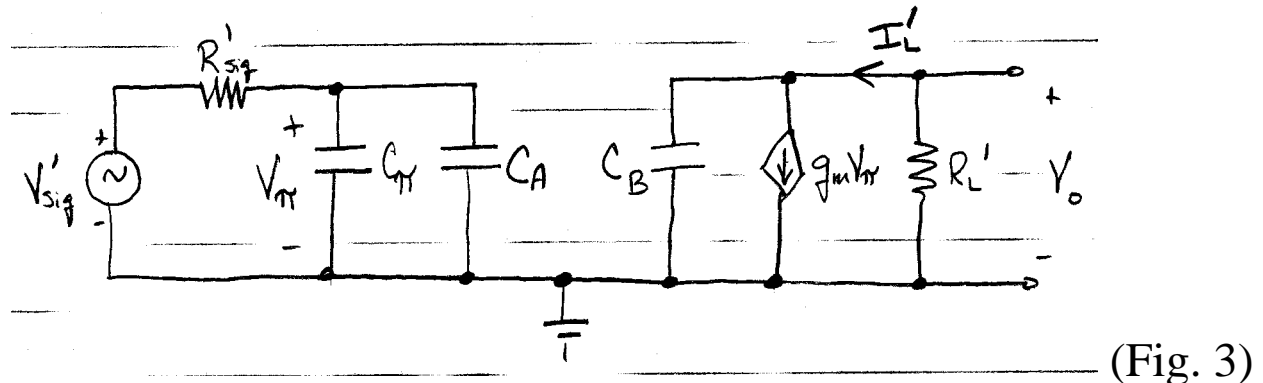

where, using (14) and (15),

$$C_A = C_\mu \left( 1 - \frac{V_o}{V_\pi} \right) \quad \text{and} \quad C_B = C_\mu \left( 1 - \frac{V_\pi}{V_o} \right) \quad (16), (17)$$

Actually, this equivalent circuit of Fig. 3 is **no simpler to analyze** than the one in Fig. 5.72b because of the dependence of  $C_A$  and  $C_B$  on the voltages  $V_o$  and  $V_\pi$ .

However, this equivalent circuit of Fig. 3 will **prove valuable for the following approximation**. Note from Fig. 5.72b that

$$I'_L + I_\mu = g_m V_\pi \quad \Rightarrow \quad I'_L = g_m V_\pi - I_\mu \quad (18)$$

Up to frequencies near  $f_H$  and better, the current  $I_\mu$  in the small capacitor  $C_\mu$  will be much smaller than  $g_m V_\pi$ . Consequently, from (18)

$$I_L' \approx g_m V_\pi \quad (19)$$

and 
$$V_o \approx -I_L' R_L' = -g_m R_L' V_\pi \quad (5.169), (20)$$

Using this last result in (16) and (17) we find that

$$C_A \approx C_\mu \left( 1 + \frac{g_m R_L' V_\pi}{V_\pi} \right) = C_\mu (1 + g_m R_L') \quad (21)$$

and 
$$C_B \approx C_\mu \left( 1 + \frac{V_\pi}{g_m R_L' V_\pi} \right) = C_\mu \left( 1 + \frac{1}{g_m R_L'} \right) \quad (22)$$

Most often for this type of amplifier,  $g_m R_L' \gg 1$  so that in (22)  $C_B \approx C_\mu$ . But as we initially assumed, the current through  $C_\mu$  is much smaller than that through the dependent current source  $g_m V_\pi$ , which ultimately led to equation (19).

Consequently, we can ignore  $C_B$  in parallel with  $g_m V_\pi$  and the final high frequency small-signal equivalent circuit for the CE amplifier in Fig. 5.71a is

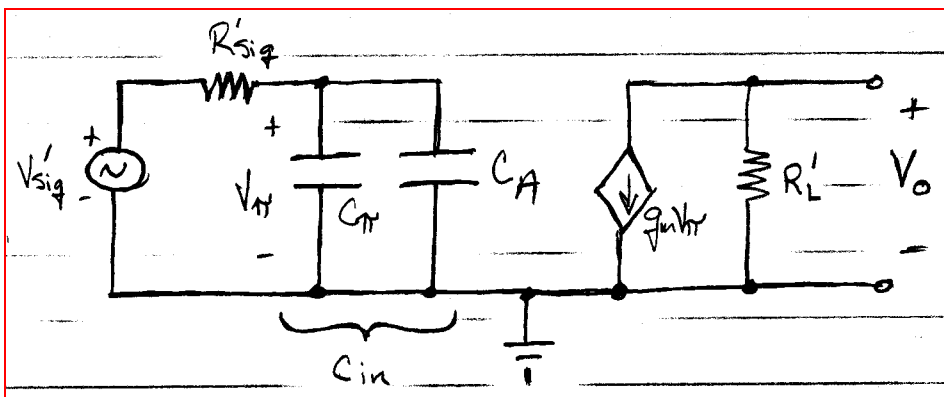

(Fig. 5.72c)



where  $C_{in} \equiv C_{\pi} + C_A = C_{\pi} + C_{\mu} (1 + g_m R_L')$  (5.173),(22)

Based on this small-signal equivalent circuit, we'll derive the high-frequency response of this CE amplifier. At the input

$$V_{\pi} = \frac{Z_{C_{in}}}{Z_{C_{in}} + R_{sig}'} V_{sig}' \quad (23)$$

while at the output

$$V_o = -g_m R_L' V_{\pi} \quad (24)$$

Substituting (23) into (24) gives

$$V_o = -g_m R_L' \frac{Z_{C_{in}}}{Z_{C_{in}} + R_{sig}'} V_{sig}' \quad (25)$$

Since  $Z_{C_{in}} = (j\omega C_{in})^{-1}$  then (25) becomes

$$V_o = -g_m R_L' \frac{1}{\frac{j\omega C_{in}}{1} + R_{sig}'} V_{sig}' = \frac{-g_m R_L'}{1 + j\omega C_{in} R_{sig}'} V_{sig}' \quad (26)$$

If we define

$$\omega_H = \frac{1}{C_{in} R_{sig}'} \quad (27)$$

then substitute this into (26) gives

$$\frac{V_o}{V_{sig}'} = \frac{-g_m R_L'}{1 + j \frac{\omega}{\omega_H}} = \frac{-g_m R_L'}{1 + j \frac{f}{f_H}} \quad (28)$$

where

$$f_H = \frac{\omega_H}{2\pi} = \frac{1}{2\pi C_{in} R_{sig}'} \quad (5.176),(29)$$

You should recognize this transfer function (28) as that for a **low pass circuit** with a cut-off frequency (or 3-dB frequency) of  $\omega_H$ . This is the response of a **single time constant circuit**, which is what we have in the circuit of Fig. 5.72c.

What we're ultimately interested in is the **overall transfer function**  $V_o/V_{sig}$  from input to output. This can be easily derived from the work we've already done here. Since

$$\frac{V_o}{V_{sig}} = \frac{V_o}{V_{sig}'} \frac{V_{sig}'}{V_{sig}} \quad (30)$$

We can use (28) for the first term in the RHS of (30), and use (5) for the second giving

$$\frac{V_o}{V_{sig}} = \frac{-g_m R_L'}{1 + j \frac{f}{f_H}} \cdot \frac{r_\pi}{r_\pi + r_x + R_B \parallel R_{sig}'} \cdot \frac{R_B}{R_B + R_{sig}'} \quad (31)$$

We can recognize  $A_m$  from (4) in this expression giving

$$\frac{V_o}{V_{sig}} = \frac{A_m}{1 + j \frac{f}{f_H}} \quad (5.175),(32)$$

Once again, this is the frequency response of a **low pass circuit**, as shown below:

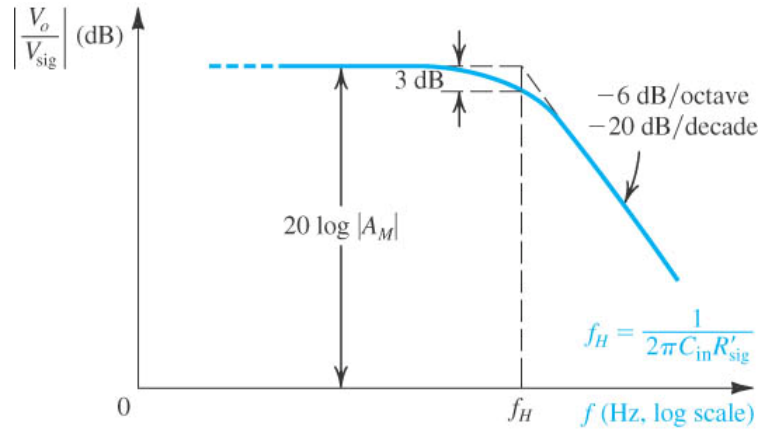

(d)

(Fig. 5.72d)

## Comments and the Miller Effect

- Equation (32) gives the mid-band and high frequency response of the CE amplifier circuit. It is not valid for the low frequency response near  $f_L$  and lower frequencies, as shown in Fig. 5.71b.
- It turns out that  $C_{in}$  in (22) is usually dominated by  $C_A = C_\mu (1 + g_m R_L')$ . Even though  $C_\mu$  is usually much smaller than  $C_\pi$  its effects at the input are **accentuated by the factor  $1 + g_m R_L'$** .
- The reason that  $C_A$  undergoes this multiplication is because it is connected between two nodes (B' and C in Fig. 5.72a) that experience a large voltage gain. This effect is called the

**Miller effect** and the multiplying factor  $1 + g_m R_L'$  in (22) is called the **Miller multiplier**.

- Because of this Miller effect and the Miller multiplier, the **input capacitance  $C_{in}$  of the CE amplifier is usually quite large**. Consequently, from (20) the  **$f_H$  of this amplifier is reduced**. In other words, this Miller effect limits the high frequency applications of the CE amplifier because the bandwidth and gain will be limited.

---

## Low Frequency Response of the CE Amplifier

On the other end of the spectrum, the **low frequency response of the CE amplifier** – and all other capacitively coupled amplifiers – **is limited by the DC blocking and bypass capacitors**.

This type of low frequency response analysis is **rather complicated** because there is **more than a single time constant response involved**. In the circuit of Fig. 5.71a there are three capacitors involved,  $C_{C1}$ ,  $C_{C2}$ , and  $C_E$ . All three of these greatly affect the low frequency response of the amplifier and can't be ignored.

The text presents an approximate solution in which the low frequency response is modeled as the product of three high pass single time constant circuits cascaded together so that

$$\frac{V_o}{V_{\text{sig}}} \approx -A_m \left( \frac{j\omega}{j\omega + \omega_{p1}} \right) \left( \frac{j\omega}{j\omega + \omega_{p2}} \right) \left( \frac{j\omega}{j\omega + \omega_{p3}} \right) \quad (5.183), (33)$$

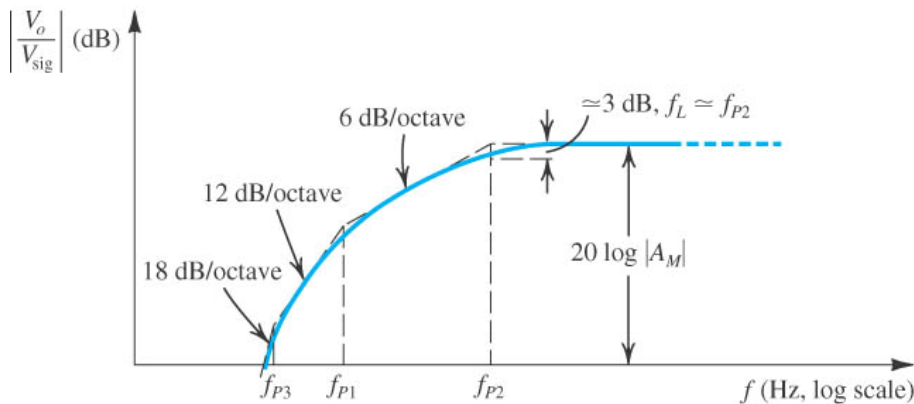

(e)

(Fig. 5.73e)

So there isn't a single  $f_L$  as suggested by Fig. 5.71b but rather a more complicated response at low frequencies as we see in Fig. 5.73e above. Computer simulation is perhaps the best predictor for this complicated frequency response, but an approximate formula for  $f_L$  is given in the text as

$$f_L \approx f_{p1} + f_{p2} + f_{p3} = \frac{1}{2\pi} \left( \frac{1}{C_{C1}R_{C1}} + \frac{1}{C_ER_E} + \frac{1}{C_{C2}R_{C2}} \right) \quad (5.184), (5.185), (34)$$

where  $R_{C1}$ ,  $R_E$ , and  $R_{C2}$  are the resistances seen by  $C_{C1}$ ,  $C_E$ , and  $C_{C2}$ , respectively, with the signal source  $V_{\text{sig}} = 0$  and the other two capacitors replaced by short circuits.

**Example N23.1.** Compute the mid-band small-signal voltage gain and the upper 3-dB cutoff frequency of the small-signal voltage gain for the CE amplifier shown in Fig. 5.71a. Use a 2N2222A transistor and the circuit element and DC source values listed in Example 5.18 in the text. Use  $10\ \mu\text{F}$  blocking and bypass capacitors.

The circuit in Agilent *Advanced Design System* appears as:

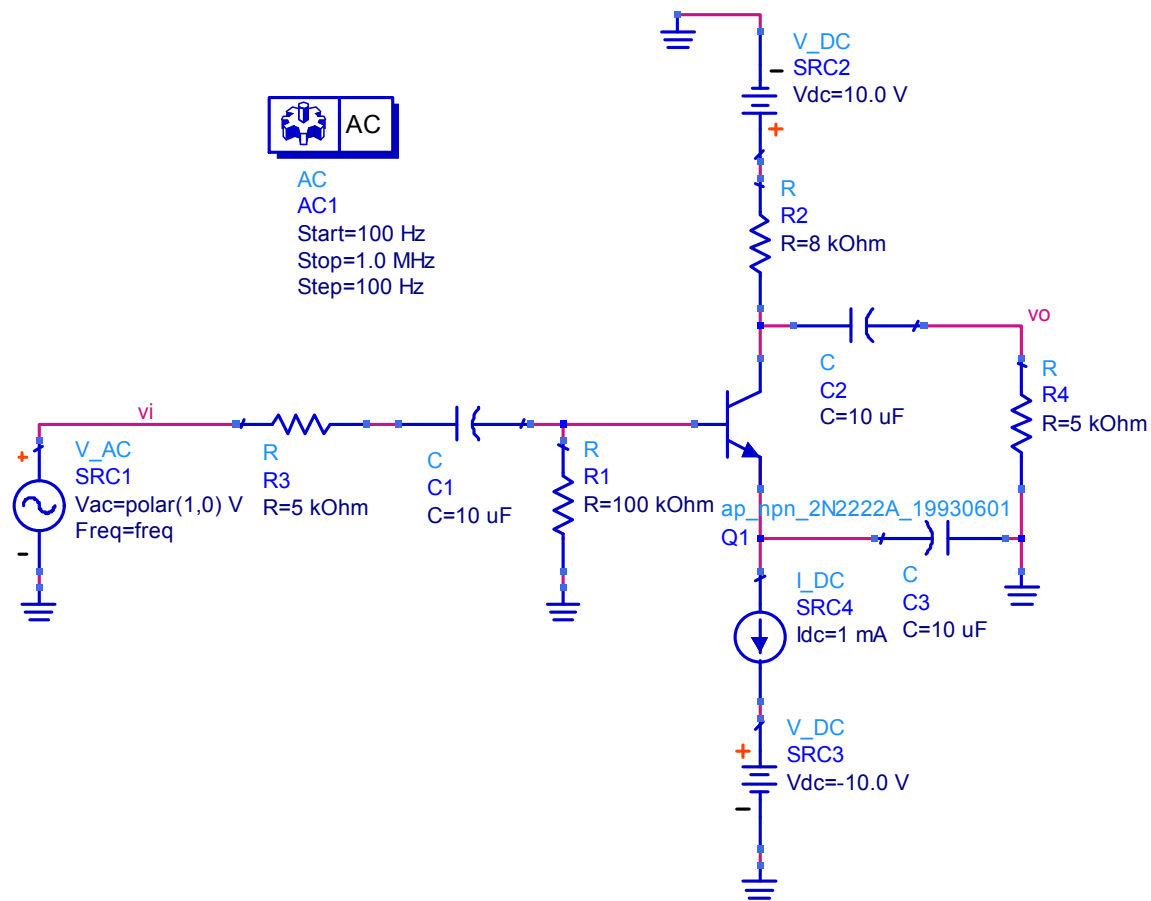

From the results of the ADS circuit simulation

$$V_{CB} = 2.03 \text{ V} - (-400 \text{ mV}) = 2.43 \text{ V}$$

$$V_{BE} = -0.4 \text{ V} - (-1.02 \text{ V}) = 0.62 \text{ V}$$

From Fig. 9 in the Motorola 2N2222A datasheet (see the previous set of lecture notes)

- For  $V_{CB} = 2.43 \text{ V} \Rightarrow C_{cb} = C_{\mu} \approx 5.8 \text{ pF}$ .
- For  $V_{BE} = 0.62 \text{ V} \Rightarrow C_{eb} = C_{\pi} \approx 20 \text{ pF}$ .

$$g_m = \frac{I_C}{V_T} = \frac{1 \text{ mA}}{25 \text{ mV}} = 0.04 \text{ S}$$

From (5.163),

$$f_T \approx \frac{g_m}{2\pi(C_{\pi} + C_{\mu})} = \frac{0.04}{2\pi(20 \text{ pF} + 5.8 \text{ pF})} = 246.8 \text{ MHz}$$

This value agrees fairly with the [datasheet value of 300 MHz](#).

$\beta_0 \approx 265$  from the ADS parts list for this 2N2222A transistor. Therefore,

$$r_{\pi} = \frac{\beta_0}{g_m} = \frac{265}{0.04} = 6,625 \text{ } \Omega$$

From the 2N2222A datasheet, the nominal output resistance at  $I_C = 1 \text{ mA}$  is  $r_o \approx 50 \text{ k}\Omega$ .

What about  $r_x$ ? It's so small in value ( $\sim 50 \text{ } \Omega$ ) that we'll easily be able to ignore it for the  $A_m$  calculations compared to  $r_{\pi}$  (which is  $6,625 \text{ } \Omega$  as we just calculated). From (4),

$$A_m = \underbrace{\frac{-g_m r_\pi}{r_\pi + r_x + R_B \parallel R_{\text{sig}}}}_{-0.02327} \cdot \underbrace{\frac{R_B}{R_B + R_{\text{sig}}}}_{0.9524} \cdot \underbrace{(r_o \parallel R_C \parallel R_L)}_{2,898.6=R_L'}$$

Therefore,  $A_m = -64.24 \frac{V}{V}$

or in decibels  $A_m = 20 \log_{10} (|A_m|) = 36.2 \text{ dB}$

From ADS:

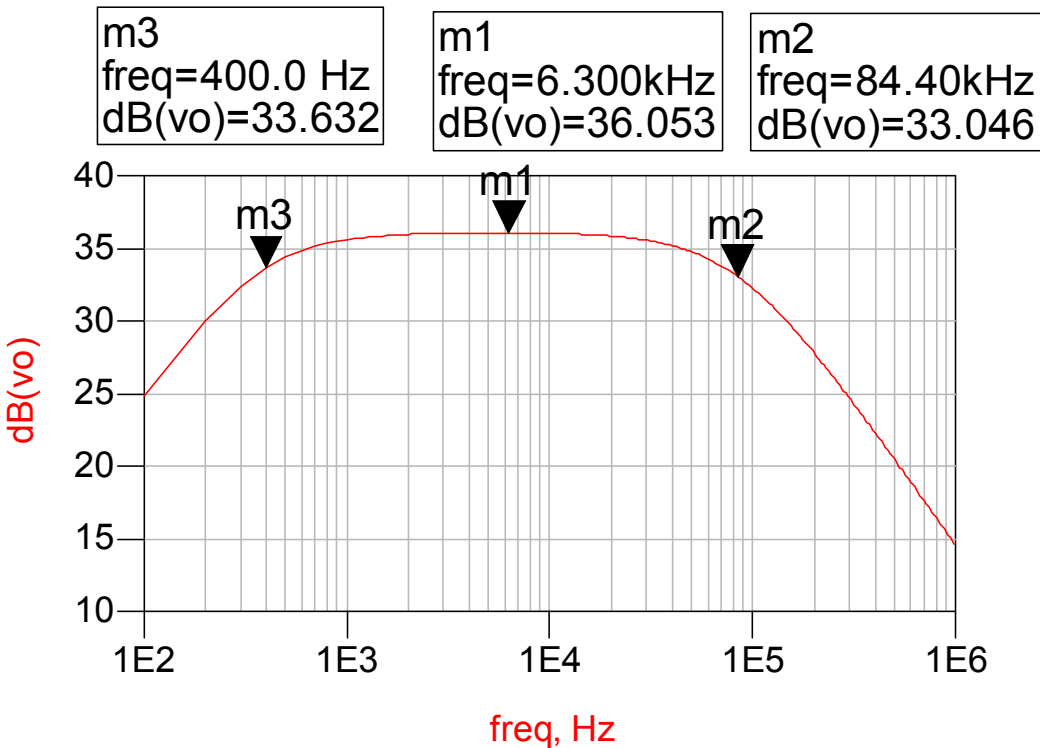

From this plot, ADS computes a mid-band gain of  $A_m = 36.05 \text{ dB}$ , which agrees closely with the predicted value above.

From (29),  $f_H \approx \frac{1}{2\pi C_{\text{in}} R_{\text{sig}}'}$



where from (22)

$$\begin{aligned} C_{\text{in}} &= C_{\pi} + C_{\mu} \left( 1 + g_m R_L' \right) = 20 + 5.8(1 + 0.04 \cdot 2,898.6) \text{ pF} \\ &= 20 + 678.3 = 698.3 \text{ pF} \end{aligned}$$

while from (6)

$$R_{\text{sig}}' = r_{\pi} \parallel \left[ r_x + (R_B \parallel R_{\text{sig}}) \right]$$

Because  $R_B \parallel R_{\text{sig}} = 100 \text{ k} \parallel 5 \text{ k} = 4,761.9 \text{ } \Omega$  is so much larger than  $r_x$  (on the order of  $50 \text{ } \Omega$ ), we can safely ignore  $r_x$ . Then,  $R_{\text{sig}}' \approx 6,625 \parallel 4,762 = 2,771 \text{ } \Omega$ .

Therefore,

$$f_H \approx 2\pi \cdot 698.3 \times 10^{-12} \cdot 2,771 = 82.25 \text{ kHz}$$

This agrees very closely with the value of 84.40 kHz predicted by the ADS simulation shown above.

---

Add a short discussion on the gain-bandwidth product  $|A_m| f_H$ .