

See discussions, stats, and author profiles for this publication at: <https://www.researchgate.net/publication/289779492>

Radio Direction Finding, Theory and Practices.

Technical Report · January 2016

CITATIONS

0

READS

18,027

1 author:



Nisar Ahmed

University of Engineering and Technology, Lahore

41 PUBLICATIONS 148 CITATIONS

SEE PROFILE

Some of the authors of this publication are also working on these related projects:



Crop Yield Forecasting [View project](#)



Multimedia Security [View project](#)

Radio Direction Finding: Theory and Practices

Written By:

Nisar Ahmed Rana

E-Mail: nisarahmedrana@yahoo.com

Cell: +92-300-7272402

Note: The document contains figures copied from some sources. However, the sources are not mentioned with figures but are listed in references list. Please check the corresponding original source if you want to cite a figure.

List of Figures

Figure 4.1: Primary ground current and its frequency spectrum (Healthy).**Error! Bookmark not defined.**

List of Tables

Table 4.1: Switches table.	Error! Bookmark not defined.
Table 4.1: Results of trans-admittance analysis in frequency-domain at Position 1.	Error!
	Bookmark not defined.

Table of Contents

List of Figures	II
List of Tables	III
Table of Contents	4
Abstract	7
1. Introduction	8
1.1. Overview	9
1.2. Principles of Direction Finding	10
1.2.1. Generation and Characterization of Electromagnetic Waves	10
1.2.2. Main Direction Finding Principles	10
1.2.3. DF based on Directional Patterns	11
1.2.4. DF by Aperture Sampling	11
1.2.5. Main Requirements of a Direction Finding System	11
1.2.6. Components of a DF System	12
1.3. Software Introduction	12
1.4. Hardware Introduction	13
1.5. Thesis Structure	13
2. Introduction to Conventional RDF Systems	14
2.1 Historical Development of Radio Direction Finding Systems	15
2.2 Theory of Operations	16
2.3 The Sensor System	18
2.3.1 Phase Measuring Antennas	18
2.3.2 Directional Antennas	19
2.4 Basic Signal Processors	19

2.5	Types of RDF techniques	20
2.5.1	Classical Direction Finding Methods	20
2.6	DF using Directional Antennas	20
2.7	Watson-Watt	22
2.7.1	Phase Comparison RDF Techniques	25
2.8	Multi-Channel Interferometer	25
2.9	True-Doppler (Single-Channel Interferometer)	27
2.10	Pseudo-Doppler (Single-Channel Interferometer)	28
2.11	Main Requirement of RDF Systems	32
3.	Pseudo-Doppler Direction Finding Method	33
3.1	Doppler Characteristics	35
3.2	Doppler Accuracy	36
3.3	Doppler Principle	37
3.4	The Doppler Sine Wave	39
3.5	Doppler Pulse Principles	40
3.5.1	Background	40
3.5.2	An Example	41
3.6	Bearing Ambiguities	43
3.7	Doppler Pulse Waveforms	43
3.8	Doppler Pulse Energy	44
3.9	Doppler Pulse Integration	45
3.10	DOPPLER DATA PRESENTATION	46
3.11	Pseudo-Doppler Antenna Phase Delay	48
4.	Comparison of Single-Channel Direction Finding Techniques	49

4.1	Watson-Watt Method	50
4.2	Advantages and Disadvantages of Watson-Watt System	53
4.2.1	Advantages	53
4.2.2	Disadvantages	53
4.3	Advantages and Disadvantages of Pseudo-Doppler System	54
4.3.1	Advantages	54
4.3.2	Disadvantages	55
	References	56

Abstract

To ensure the integrity of their insulation, power and distribution transformers are subjected to a sensitive high-voltage impulse testing. This sensitive test is performed by applying a standard 1.2/50 μ s high-voltage impulses across the windings of a transformer and waveforms of voltage and current are recorded. In case of major faults inside a transformer there will be a considerable deviation between healthy and faulty waveforms so the detection of such faults is an easy task. It can be done by the visual inspection of the time-domain impulse voltage and neutral current waveforms. But in case of a minor incipient fault, the time-domain waveforms show no deviation. So the fault-detection capability can be enhanced by analyzing the waveforms in frequency-domain. For this purpose many frequency response analysis techniques have been reported in the past few years.

The fault-detection sensitivity can be increased by analyzing the ratio of current and voltage in frequency-domain rather than the analysis of current and voltage waveforms separately. If the ratio is computed by considering the primary current and the secondary voltage of a transformer, it is referred as 'trans-admittance' of the transformer.

This research work proposes a novel technique to enhance the fault-detection sensitivity to a new level. This technique is based on the analysis of the trans-admittance of distribution transformers with the help of continuous wavelet transform (CWT). The performance of proposed technique was evaluated by comparing its results with the analysis results obtained by using Fourier transform (FT) and short time Fourier transform (STFT), and it is concluded that the trans-admittance analysis of a transformer with the help of CWT improves the sensitivity of fault detection.

Chapter 1

Introduction

1.1. Overview

A radio direction finding (DF) system is an antenna array and a receiver arranged in a combination to determine the azimuth angle of a distant emitter. Basically, all DF systems derive the emitter location from an initial determination of the angle-of-arrival (AOA). Radio direction finding techniques have classically been based on multiple-antenna systems employing multiple receivers. Classic techniques such as MUSIC [1, 2] and ESPRIT use simultaneous phase information from each antenna to estimate the angle-of-arrival of the signal of interest. In many scenarios (e.g. Hand-held systems), however, multiple receivers are impractical. Thus, single channel techniques are of interest, particularly in mobile scenarios. Although the amount of existing research for single channel DF is considerably less than for multi-channel direction finding, single channel direction finding techniques have been previously investigated. When considering single channel direction finding systems, we find that there are two distinct types of DF systems. The first type of DF system is the amplitude-based DF system.

Amplitude-based systems determine the bearing of the signal (or the AOA) by analyzing the amplitudes of the output voltages from each antenna element. Amplitude DF systems include the Watson-Watt technique using an Adcock antenna array [3].

The second type of DF system is the phase-based DF system. Phase-based systems use three or more antenna elements that are configured in a way so that the relative phases of their output voltages are unique for every wave front angle-of-arrival. Phase-based DF systems include the Pseudo-Doppler technique with a commutative switch based antenna array [3].

Although RDF systems are available in market and we can select state of the art system of our interest with any specific RDF technique but as these systems are normally used in security and law enforcement agencies so complete design of system is not available for research.

This thesis is a design document of pseudo Doppler RDF system in which fine details of design are discussed. Design is limited to antenna array and switching scheme only. After getting signal from antenna array we can use standard RF to IF receivers and further processing hardware.

1.2. Principles of Direction Finding

1.2.1. Generation and Characterization of Electromagnetic Waves

Electromagnetic waves are generated by charging and discharging on electrical conductors that can be characterized in the form of alternating currents [3, 4]. Assumptions for generation and characterization of electromagnetic waves are in pace with the propagation of harmonic wave of wavelength λ . At a reasonable large distance, the wave can be treated as plane because the radial field components of an EM waves are decayed. The electric and magnetic components of the EM waves are orthogonal to each other and to the direction of propagation that can be defined by Poynting Vector \vec{S} .

$$\vec{S} = \vec{E} \times \vec{H} = \vec{e}_0 \frac{|E|^2}{Z_0}$$

Here, E =root mean square value of electric field, Z_0 is specific impedance of free space which is approximately equal to $120. \pi \Omega$.

$$\vec{k} = \vec{e}_0 \frac{2\pi}{\lambda}$$

1.2.2. Main Direction Finding Principles

Direction finding is based on the basic principle of EM waves, which are provided below:

- Transversality, which states electric and magnetic field vectors are perpendicular to the direction of propagation
- Orthogonality, which states that electric and magnetic fields are orthogonal to each other and to the direction of propagation

All direction finding systems fundamentally employs on of the following methods:

Method A (Polarization DF): determine the direction of electric/magnetic field.

Method B (Phase DF): determines the orientation of line of equal phase.

Polarization direction finder are realized by the use of loop and dipole antennas. The historical rotating-loop direction finder is of this category. The loop is rotated to minimum received signal level to determine the incident wave as it would be perpendicular to the loop. Polarization direction finders are used for in vehicle with small antennas in HF band. Watson-Watt method is used for evaluation and to obtain explicit bearings.

Phase direction finder acquires the bearing information from the spatial orientation of lines of equal phase. There are two methods:

1.2.3. DF based on Directional Patterns

In this method, a sum signal is formed by coupling out partial waves at various points in the antenna system. The maximum value of sum is obtained at an angle where these phase differences are minimum. For maximum-signal direction finding, the sum signal is always orthogonal to the phase surface of the incident wave. Whereas for minimum-signal direction finding, the partial waves are combined in such a way that phase differences are maximum in the direction of incident wave.

1.2.4. DF by Aperture Sampling

In this method, an evaluation circuit is used to process the samples taken at various points of the field. Evaluation circuit determines bearing by linking the samples, which is mostly done by mathematical operations.

Interferometers and Doppler direction finder are the typical examples of phase direction finders.

The direction finding methods discussed so far are only suitable to a limited extent for measuring the bearings of several waves that overlap in frequency domain. Spectral estimation methods provided by the digital signal processing are applied to wavefront analysis. Sensor array processing is a term which describes the method of obtaining value of parameters of incident waves from the signals acquired from the antenna array. There are three basic methods:

- Beam forming methods: adaptive antenna, correlation direction finder and spatial Fourier analysis
- Maximum likelihood method: most general model-based method
- Subspace methods: ESPRIT and MUSIC

1.2.5. Main Requirements of a Direction Finding System

A direction finding system must fulfill the following requirements.

- High sensitivity
- High precision
- High scanning speed

- Large signal immunity
- Immunity to polarization mismatch
- Immunity to multipath propagation effect
- Steady behavior towards non-coherent interferers

1.2.6. Components of a DF System

A radio direction finding system consist of the following parts

- Antenna system
- Direction finding converter
- Evaluation unit
- Display unit

GPS coordinate finding system, remote units, antenna control unit and some other components can be a part of a radio direction finding system. The need of these components depends on the configuration of the system used for direction finding.

The speed of direction finding system depend on the number of receive sections which determines the number of parallel antenna outputs. Monopulse direction finding, using one set of samples to determine the bearing angle, is used to achieve the maximum direction finding speed as it calculate the bearing in single step. For an accurate direction-finding there must be at least three antennas to cover the whole azimuth at an angle of 120° .

To achieve high direction finding accuracy and more bandwidth, 5-7 aperture samples are commonly required. If monopulse direction finding systems is used, it will result in very complex result. Oftentimes, one fixed and two consequently switched receive stations are used to avoid the complexity.

1.3. Software Introduction

Simulation of pseudo Doppler RDF is done in Matlab 2010. Radiation pattern of antenna array is studied in CST STUDIO 2012. PCB is designed in Altium Designer 2009.

1.4. Hardware Introduction

In circular antenna array 1126DS RF switches are used for switching an antenna element to input side of RF receiver. 89c2051 microcontroller is used for controlling all RF switches to provide a unique path for the signal.

1.5. Thesis Structure

Chapter 2 is the introduction and the comparison of some commonly used RDF techniques. The techniques which are discussed are Watson watt RDF with Adcock antennas, pseudo Doppler RDF and phase interferometer. After discussing algorithm of these techniques pros and cons of each technique is discussed.

Chapter 3 is detailed description of Doppler and pseudo Doppler RDF technique. Basic mathematical model of pseudo Doppler is discussed. Some other mathematical model are also discussed to process the received signal to find angle of arrival (AOA). Result of Matlab simulation of basic pseudo Doppler RDF algorithm are discussed.

Chapter 4 includes discussion about radiation pattern of monopole antenna array and effect on radiation pattern if we fix monopole antenna on the edge of ground plane.

Chapter 5 is about hardware design which includes monopole antenna design, micro strip design and complete PCB design

In chapter 6 we will discuss results of our hardware and see the effect of multipath reception SOI.

Chapter 2

Introduction to

Conventional RDF

Systems

This chapter briefly discusses the basic concepts of Direction Finding (DF) systems and highlights some conventional direction finding algorithms. Three of the most important algorithms discussed are pseudo-Doppler direction finding technique, Watson-Watt or Adcock antenna array and correlative interferometer.

2.1 Historical Development of Radio Direction Finding Systems

Radio direction finding (RDF) is the mechanism of direction measurement for RF signal emitter. Direction measurement results of multiple sources or a single source can be combined to locate the source of a transmitter through triangulation. RDF is also used for direction finding in aircrafts and ships and for location of transmitter for search and rescue. It is also useful for wildlife tracking and location of an illegal transmitter.

RDF is pretty old-field dating back to radio itself. In 1888, Heinrich Hertz discovered about the antenna directivity while conducting experimentations in the decimetric wave range. In 1906, Scheller patented a specific application of this discovery for direction determination of electromagnetic wave. Initially polarization direction finders were the initial direction-finding units. Their manufacturing was based on rotatable magnetic or electric dipoles, which were directed towards the direction of electric or magnetic field. This polarization direction was used to determine the direction of incidence. Rotating-loop direction finders were the best known direction-finding devices of this type. Two or more bi-directional loop antenna arrays were employed to manufacture these early devices. A goniometer, which is a 2- or 3-phase mechanical resolver, was used to take input from this antenna array to show the direction of incoming signal through deflection coil. Bellini-Tosi system was one of the earliest and prominent direction finding systems used in those days. It used two triangular loop antennas, arranged at right angles. The signals from these antennas were fed to a coil wrapped around a wooden frame and signals were recreated again. A separate loop antenna placed in its vicinity then search for the direction without the need to move the main antenna. This phenomenon made RDF more practical and resulted in first aerial navigational system available.

These early direction-finding systems failed for direction finding applications at higher frequencies. Reflection due resulted in difficulty to find direction as the RDF receives the signal from multiple sources due to ionosphere reflections. Loop-based system worked well for vertically polarized signals but failed badly when horizontally polarized signal components

start appearing at night. This issue of skyways caused very unreliable bearings and it was absent completely at low frequencies during daylight. This problem was avoided by Adcock antenna, which consisted of two pairs of monopole antennas instead of two loops. This method was developed and patented by an Englishman Adcock in 1919 namely Adcock DF antenna. This antenna principally relied upon suitably spaced differential dipole elements to obtain the bi-directional antenna gain pattern with circular lobes. As the vertical elements of this antenna were made almost resistant to the effects of horizontally polarized signals, it can provide good bearings even in presence of skyways.

This twin channel DF system was further improved by R. A. Watson-Watt who is also known by his key role in development of early British radar technology. In 1930s, the availability of cathode ray tubes replaced the mechanical pointer display at least in sophisticated systems. These antennas were extensively used after 1920s along with Bellini-Tosi detectors. Another major breakthrough in direction finding was the introduction of real-time polar cathode ray tubes based bearing display. As the trace-length of cathode ray tube allowed the operator to easily discriminate between the desired and undesired multipath. Watson-Watt direction finding systems employing single and multi-channel methodology were manufactured during this time with operating range up to VHF. In 1931, US Army Air Corps successfully tested a naive radio compass utilizing commercial transmitting beacons.

After World War-II, Doppler and pseudo-Doppler direction-finding systems came to prominence. Pseudo-Doppler are essentially a special single channel implementation of interferometer direction finding systems. Multi-channel interferometers were used prior to World War-II. Godfrey and Earp first introduced the concept of single channel interferometer in 1947. In 1943, the first direction finder for radar observation operating on Doppler principle at 3GHz was manufactured [5]. Since 1950, airports around the globe are equipped with Doppler direction finding systems. The main improvement provided by pseudo-Doppler over Adcock was its ability to implement as a wide-aperture array capable of reducing errors due to multi-path interference.

2.2 Theory of Operations

The operation of direction finding systems can be broken down in terms of three basic subsystems: the sensor system, the signal processor, and the display. Each of these subsystems

is discussed in the following subsections. In discussing the theoretical aspects of the operating principles of direction finding systems, several assumptions are implicit (unless otherwise indicated):

- a) The signal follows a single, direct, unobstructed path from the transmitter to the direction finding system
- b) There are no interfering signals
- c) The signal wavefront is planar
- d) The angle of arrival of the signal in elevation is 0 degrees
- e) The signal is vertically polarized
- f) The signal is continuous wave
- g) The measurement equipment is perfect
- h) Noise is absent

The problems with real world systems when these assumptions break down and the solutions to these problems will be discussed in a later section.

To simplify discussion, a number of terms and conventions have been used throughout the rest of this report. The term "channel" is used to describe a signal path through the direction finding system. For example, two signals occupying the same channel, share the same circuitry, but not necessarily the same frequency band.

The term "receiver front end" is used to describe the first input stage(s) of the receiver which shift the radio frequency (RF) signal to an intermediate frequency (IF), amplify it, and pass it through a bandpass filter. The bandwidth of the filter controls the receiver bandwidth.

Phase delays introduced by equipment components are assumed to be equal in all signal paths. Under this assumption, phase delays have no effect on direction finding system operation, except where stated otherwise. Amplitude gains and losses are also assumed to be equal in all signal paths.

In the text that follows all angular measurements are expressed in degrees where the convention -180 to +180 degrees has also been adopted. In equations, however, the corresponding radian measure is used.

The arc tangent function used in the form

$$\phi = \text{arctan}\left(\frac{Y}{X}\right)$$

throughout the discussion uses the signs of X and Y ("+" or "-") to correctly determine the quadrant of ϕ .

In the mathematical derivations that follow, the RF signal is assumed to generate a voltage in a matched dipole antenna of the form

$$s(t) = V_d \sin(\omega t + \gamma) \text{ Volts}$$

where the parameters of the equation are defined in the following paragraph. The phase angle γ is defined to be 0 degrees if the dipole is located at the geometric center of the antenna array of which it is a part. Finally, a number of parameters are used repeatedly throughout this section. They are defined here as:

t = Time (seconds),

ω = Signal frequency (radians/second),

λ = Signal wavelength (meters),

ϕ = True signal bearing in azimuth referenced to true North (radians),

ϕ_c = Bearing computed by the direction finding system (radians),

d = Distance between a pair of antennas (meters),

V_d = Maximum voltage induced in a matched dipole antenna (Volts),

γ = Signal phase (radians).

2.3 The Sensor System

The sensor system electrically couples the direction finding system to the radio signal environment. It consists of an array of two or more antennas which supply the appropriate signal information to the signal processor. There are essentially two different types of antennas used in the sensor system: phase measuring, and directional.

2.3.1 Phase Measuring Antennas

The vertical dipole antenna is used for making phase measurements. The ideal voltage gain pattern (in azimuth) of this antenna is Omni-directional, making the antenna equally sensitive to signals arriving from any direction.

Phase measurements are made indirectly. The dipole antenna measures the instantaneous amplitude of a signal at a specific point in space. The voltage generated in the antenna is given by the equation

$$V(t) = V_d \text{Sin}(\omega t + \gamma) \text{ Volts}$$

By comparing the antenna voltage to a second dipole antenna voltage, the relative phase angles between the two antennas can be determined. In direction finding antenna arrays where one antenna is used as a reference (for phase comparison purposes), this antenna is known as a "sense" antenna.

2.3.2 Directional Antennas

The ideal voltage gain pattern (in azimuth) of a directional antenna used for the Watson-Watt system is given by the equation.

$$\text{Gain} = G_{max} \text{Cos}(\phi)$$

Here G_{max} is the maximum gain of the antenna. Due to the cosine form of the gain equation, this voltage gain pattern is often called the cosine pattern. It is apparent that, unlike the Omni-directional phase antenna, the voltage gain of this antenna is highly dependent on the direction of arrival of the signal.

Real world directional antennas for direction finding systems are constructed from two or more dipole elements. The actual voltage gain patterns are not true cosine patterns, but rather, approximations of it. Since deviations from the true cosine pattern result in errors in the bearing measurements, design of real world antenna arrays tries to minimize the cosine deviations.

2.4 Basic Signal Processors

Signal processing can be regarded as a three-step process: frequency down conversion, demodulation, and bearing computation. A receiver down converts and amplifies an RF signal to a fixed intermediate frequency (IF). The demodulator, which may be part of the receiver, or in a separate unit, converts the signal from IF to a form suitable for the bearing processor that computes the bearing.

In some systems, the demodulated input signal to the bearing processor is not suitable for audio purposes (i.e. cannot be used by the direction finding operator to listen to the intercepted signal). If the demodulator used for the bearing processor is separate from the receiver, the

receiver demodulator can be used to convert the signal to audio; otherwise, a separate receiver may be required for this purpose.

There are three basic types of direction finding systems: Watson-Watt, pseudo-Doppler, and phase interferometer. The signal processing requirements of each of these systems are different.

2.5 Types of RDF techniques

Although different types of direction finding system exist but there are only three types of conventional direction finding systems that can meet the current technical requirements. These systems are:

- a) Watson-Watt
- b) Pseudo-Doppler
- c) Phase interferometer

These systems are conventional in the sense that they have reached a mature state of development. For example, the Watson-Watt system was first proposed in 1926 [6], the pseudo-Doppler system in 1947 [7], and the phase interferometer system around 1961 [8]. All of these three systems were principally designed for HF band but later modified to operate in VHF and UHF frequency bands.

There are three basic types of conventional systems: Watson-Watt, pseudo-Doppler, and phase interferometer. The signal processing requirements of each of these systems are different.

2.5.1 Classical Direction Finding Methods

Following sections provides some classical direction finding methods. These methods mainly rely of analog processing of signals. Due to their simplicity and ease of implementation, some of these methods are still in practice today. However, modern direction finding systems practice complex digital signal processing techniques to find the direction of incident wave.

2.6 DF using Directional Antennas

The simplest way of direction finding is to use a mechanically rotated direction antenna. The antenna is rotated along the complete azimuth and the received voltage is evaluated. The bearing is estimated from the receive voltage as a function of azimuth rotation of antenna. The receive pattern position relative to rotation angle provide the bearing [5]. This type of direction finding method is known as phase direction finder as the directivity is obtained by

superimposing the waves with their phase depending on angle or arrival. In its simplest form, an operator rotate the antenna and check the receive voltage level. When an assumed maximum receive voltage is obtained the direction is measured from a calibrated scale attached with the antenna. In a fully automatic direction finder based on this principle, the antenna is permanently rotated with a motor to form a rotating direction finder (figure 1). The receive voltage is plotted as a function of angle of antenna rotation. An automatic receive voltage evaluation mechanism such as maximum detector, can be cascaded to form a fully automatic direction finding system. Following are the benefits of this type of direction finding system:

- High sensitivity due to antenna directivity
- Easy and economical setup
- Multi-wavefronts can be resolved with the help of high directivity antennas
- Direction finding and monitoring can be done with same antenna

This method result in some draw backs which are due to the directivity characteristics of antenna and due to limited antenna rotation speed.

- Directivity is reciprocal to probability of intercept
- Short duration signals can be processed effectively due to slow scanning speed

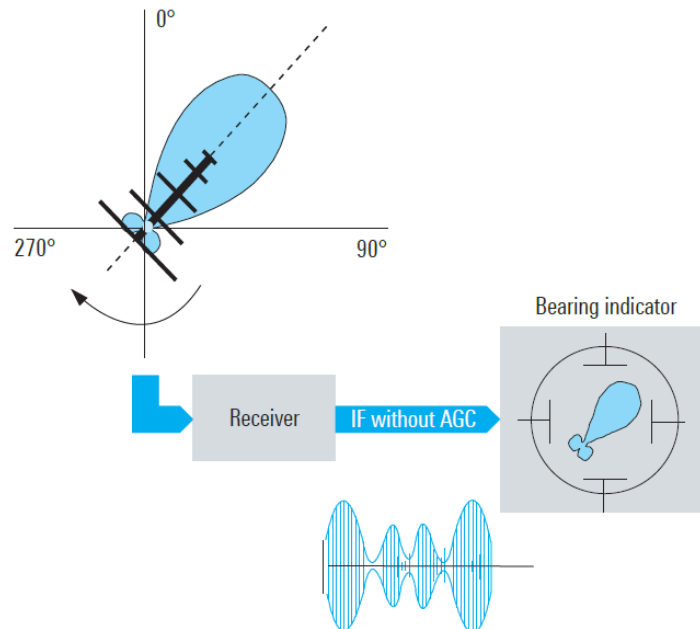

Figure 1 Direction finding using directional antenna.

Regardless of the drawbacks, direction finding methods based on mechanically rotated antennas are still used as the advantages associated with them require very high cost and effort to attain with other methods. In high frequency range such microwave, this type of systems are the only feasible option in terms of low noise, gain and cost.

Bearings can be obtained with a slowly rotating antenna if the directional pattern with a minimum in the direction of arrival is used along with a maximum. This configuration will result in a monopulse direction finding systems that operate successfully as the incident waves are on the main receiving direction. Figure-2 shows an implementation of the concept using log-periodic dipole antennas.

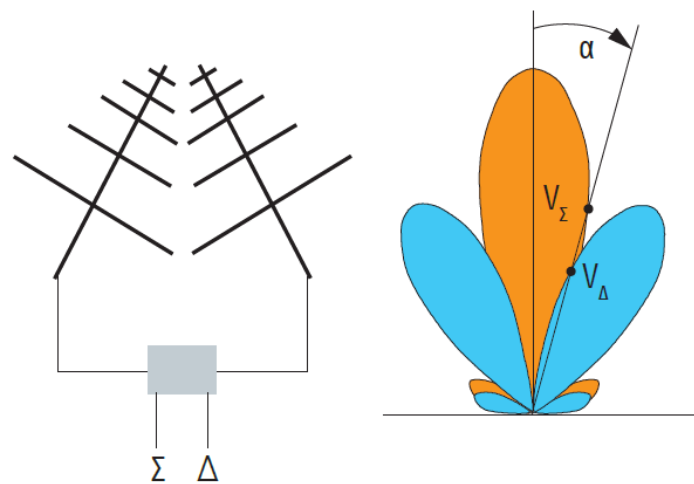

Figure 2 Direction finding using sum-difference method.

The quotient of sum and difference signals produce a time-independent and dimensionless function known as direction finding function.

$$PF(\alpha) = \frac{V_{\Delta}(\alpha)}{V_{\Sigma}(\alpha)}$$

After calculating the quotient $PF(\alpha)$, the bearing α is obtained.

2.7 Watson-Watt

The Watson-Watt system works by measuring the magnitude of the signal vector along two orthogonal axes. These quantities are then used as the arguments of the arctangent function to compute the signal bearing.

A block diagram of a Watson-Watt system is shown in Figure 3. The magnitudes of the two orthogonal signal vector components are measured using two perpendicularly oriented directional antennas. At VHF and UHF frequencies Adcock antennas are used as they are required to have cosine gain patterns. Mathematically, the output signals from these antennas can be expressed as:

$$X(t) = V_a \cos(\varphi) \cos(\omega t) \text{ Volts}$$

$$Y(t) = V_a \sin(\varphi) \cos(\omega t) \text{ Volts}$$

Here V_a is the maximum antenna output expressed in Volts. Note that the Cosine approximations for Adcock antennas are used here.

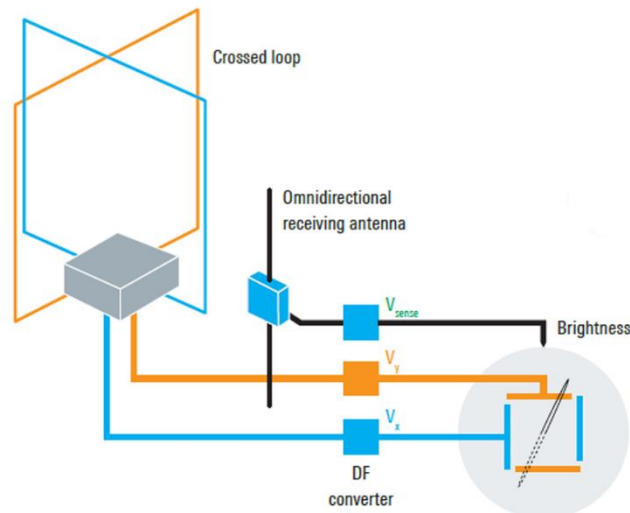

Figure 3 Working diagram of Watson-Watt Method

After conversion of the RF signal to IF by the receiver, the signals are passed to a synchronous demodulator. In the demodulator, the mixer multiplies the reference signal with each of the two input signals $X(t)$ and $Y(t)$. The reference signal can be described mathematically as

$$R(t) = V_r \cos(\omega t) \text{ Volts}$$

Here V_r is the maximum voltage expressed in Volts. The low pass filter removes any high frequency components, and the resultant outputs are then given by

$$X = V_0 \cos(\varphi) \text{ Volts}$$

and

$$Y = V_0 \sin(\varphi) \text{ Volts}$$

Here V_0 is the maximum voltage expressed in Volts. The quantities X and Y are then used to compute the bearing angle using the equation

$$\varphi_c = \text{arcTan}(Y/X)$$

The solution to φ_c is unique only if the reference is derived from a signal whose phase is independent of the signal bearing. This can be done in one of two ways. In the first method, the output from a dipole sense antenna, positioned at the geometric center of the array, is utilized. The sense output from this antenna can be expressed mathematically as

$$Se(t) = V_s \sin(\omega t) \text{ Volts}$$

Here V_s represents the maximum signal magnitude expressed in volts. In the second method, the outputs from each dipole of the Adcock antennas are summed to give the sense output given as

$$Se(t) = V_s' \sin(\omega t) \text{ Volts}$$

In this case, the magnitude of V_s' has some dependence on the signal bearing. This magnitude is always non-zero and positive as long as the diameter of the antenna array does not exceed 0.7 of a wavelength. In either case, the sense signal is amplified and phase shifted by +90 degrees to give the required reference signal

$$R(t) = V_r \cos(\omega t) \text{ Volts}$$

The main advantage Watson-Watt method is capable of monopulse direction finding, it can provide bearing immediately over the entire azimuth. Suitable antennas (sine or cosine shaped) used with Watson-Watt system are following:

- Monopole or dipole Adcock antennas
- Ferrite or loop antennas

Crossed-loop antennas are mainly suitable for mobile applications due to their compacted size.

Main advantages and drawbacks of these antennas are provided below:

Advantages:

- Compact size
- Simple implementation
- Can operate in extremely short duration signals

Drawbacks

- Causing errors in multipath situation due to small-aperture
- Erroneous direction finding results during skyways with sharp elevation angles

Adcock antennas have the following benefits over the crossed loop antennas:

- Better error resistance for skyways
- Reduced errors due to multipath effects (by implementation of wider apertures)

2.7.1 Phase Comparison RDF Techniques

In phase-comparison radio direction finding systems, more than three antennas are arranged in such a configuration that relative phase of their voltages are distinct for every angle of arrival. By appropriately processing the phases of these voltages, directions of arrival are calculated. This type of direction finding systems includes the simple interferometers and its derivatives, Doppler and pseudo-Doppler methods.

2.8 Multi-Channel Interferometer

The interferometer direction-finding systems were first used in radio astronomy [9]. The purpose of these systems was to increase the sensitivity and resolution power of direction finding systems by overlapping the signals of some antennas. This overlapping pattern is weighted against the directional pattern of antennas to obtain the bearing.

The azimuth and elevation can be efficiently determined by using three or more omnidirectional antenna elements with a spacing less than half wavelength. The azimuth with phase angles φ_1 , φ_2 and φ_3 can be calculated as:

$$\hat{\alpha} = \text{arcTan} \frac{\varphi_2 - \varphi_1}{\varphi_3 - \varphi_1}$$

The angle of elevation is obtained as

$$\hat{\varepsilon} = \text{arcCos} \frac{\sqrt{(\varphi_2 - \varphi_1)^2 + (\varphi_3 - \varphi_1)^2}}{\frac{2\pi a}{\lambda}}$$

Usually the antenna configuration is enhanced by additional installation of antenna elements to the three-antenna configuration so the spacing can be optimally reformed to operating frequency. The spacing is changed to $\frac{\lambda}{2}$ to increase the small-aperture direction finding system accuracy [5]. Commonly used antenna configurations are circular array and isosceles triangle. Circular arrays are usually preferred for higher frequencies whereas for less than 30 MHz, triangular antenna configurations are used. Preference of circular array configuration at higher frequencies is due to the following reasons:

- Antenna elements have equal radiation coupling
- Minimum radiation coupling is ensured with antenna mast
- Direction independence is ensured due to their symmetric characteristics

Avoiding ambiguities can be achieved by restricting the range to $\pm 180^\circ$. A three-channel interferometer meets these requirements successfully if distance between elements is equal to half of the minimum operating signal wavelength. Following possibilities are there for multi-element interferometer:

- Keep the phase difference below 180° for adjacent antenna elements (filled antenna arrays)
- Phase difference is greater than 180° between at least one pair of adjacent elements (thinned antenna array)

Such ambiguities are avoided by exposing the signals to a correlative interferometer.

Principle of interferometer is based in comparing phase differences obtained by a direction-finding antenna of known configuration with measured phase differences. The assessment of phase difference is done by calculation of correlation coefficient of these two datasets. The result of maximum correlation coefficient gives the bearing for corresponding azimuth direction. The complexity of computational algorithm varies from very simple to very complex, depending on the nature of the implementation. In its simplest configuration, a computer

system is required to implement the algorithm due to which interferometer was not used prior to World War-II.

Multichannel correlative interferometers are sophisticated direction finding systems with remarkable performance. These interferometer based direction finding systems are capable of overturning bearing errors caused due to multipath effects. Contrarily, these interferometers require separate receive system for each antenna making it complex, expensive and cumbersome. Consequently, they are only used at sophisticated fixed-site direction finding application where all this setup and cost can be justified. Generally, they are not justified and used for mobile and economical direction finding applications.

2.9 True-Doppler (Single-Channel Interferometer)

Earp and Godfrey of Standard Telephones & Cables, Ltd. first introduced the concept of Doppler direction finding systems in 1947. The true Doppler direction finding systems is truly a single-channel implementation of interferometer.

The operating concept of True Doppler direction finding system is based on well-recognized concept of “Doppler Shift” which states, the apparent frequency of a transmitted wavefront to a moving object is affected by its velocity. If an antenna rotates circularly with a radius R , the received signal with frequency ω_0 is frequency modulated with rotational frequency ω_r of antenna due to Doppler shift. If the antenna rotates away from the radiation source, the apparent receive frequency decreases due to rarefaction of the received wave and if the antenna moves towards the radiation sources, the apparent receive frequency increases due to compression of the received wave. Equally, the Doppler Effect is proportionally more prominent at higher velocities.

A familiar example of Doppler shift is the frequency of railway-crossing warning bell as experienced by a passenger on train. As the train moves towards the railway-crossing, the apparent pitch of the warning bell increases and when the train moves away from the railway-crossing the apparent pitch of the warning bell apparently decreases.

The most basic Doppler direction finding system used this effect to construct a Doppler direction finding systems. A single receive antenna is placed on the edge of a fast moving turntable and its rotation speed is accurately adjusted by servo controlled by a low-frequency

rotating tone generated in direction finding processor. With the antenna moving towards the transmitter, the apparent receive frequency increased and when the antenna moved away from the transmitter this frequency decreased. As a result, the received signal becomes frequency-modulated at a rate of rotational frequency. This signal is fed to an FM receiver, which recovers the rotational frequency signal through demodulation. This rotational frequency is exactly equal to rotational frequency of the turntable but its phase would be offset from the rotational frequency. It can be understood that the phase difference between the recovered frequency and original rotational frequency relates to the bearing of the received signal.

The instantaneous amplitude provides

$$u(t) = a \cos(\varphi(t)) = a \cos\left(\omega_0 t + \frac{2\pi R}{\lambda_0} \cos(\omega_r t - \alpha) + \varphi\right)$$

The instantaneous frequency is obtained by differentiating the phase

$$\omega(t) = \frac{d\varphi(t)}{dt} = \omega_0 - \frac{2\pi R}{\lambda_0} \omega_r \sin(\omega_r t - \alpha)$$

Filtration of DC component ω_0 , the obtained Doppler signal is

$$S_D = \frac{2\pi R}{\lambda_0} \omega_r \sin(\omega_r t - \alpha)$$

This demodulated signal is compared with a reference voltage of same center frequency as the one generated from antenna rotation to check their phase. The result of this phase comparison will provides the bearing a [5].

$$S_r = -\sin \omega_r t$$

2.10 Pseudo-Doppler (Single-Channel Interferometer)

The true-Doppler implementation described in section 2.9 is simpler and easy to understand but it suffers from some practical limitations. It is very difficult to rotate the turntable with enough modulation frequency to obtain a reasonable SNR (signal to noise ratio) at the demodulator output with typical IF bandwidths. In fact, rotation of antenna element is neither desirable nor it is possible at higher frequencies. Moreover, a mechanically rotating array of antenna elements will be unreliable, expensive and clumsy.

These practical limitations were overcome by replacing the rotating turntable with several antenna elements such as dipoles, crossed-loops or monopoles in a circular fashion and

electronically excited (cyclic scanning). At least three discrete antennas, equiangularly positioned alongside the perimeter of a circle. The electronic excitation was used to simulate the motion of turntable by sequentially commutating with the help of diodes. For more elaboration, in a four element antenna, first the East element is excited followed by South, West and North elements.

For unambiguous direction finding results, the spacing between antenna elements must be kept less than half the wavelength of operating frequency. Practically, the spacing is kept one third of the minimum operating wavelength. Adhering to this rule, Doppler direction finding antennas of any size can be constructed.

This pseudo-Doppler implementation of the interferometer has two inherent advantages over the true-Doppler implementation. First, the awkward mechanical rotation mechanism is eliminated. Secondly, a higher rotational tone can be used that will result in increased sensitivity due to better recovery of output tone from FM demodulator.

Wide-aperture direction finding systems with the below mentioned features can be easily implemented:

- High sensitivity
- High multipath immunity

Inherent drawback associated with the Doppler method is amount of time it requires. As a minimum, one antenna rotation is required to calculate the bearing. At usual rotating frequency of 170 Hz in UHF range, one scanning cycle takes approximately 6 ms.

In the single channel pseudo-Doppler system, omnidirectional antennas are arranged in a circle with constant spacing. Each antenna is sampled sequentially to simulate the effect of a single antenna being rotated in a circle, the effect of which is to phase modulate the signal at a frequency identical to the rotation frequency. A vector drawn from the center of the array to the simulated antenna aligns directly with the signal source when the instantaneous phase angle of the modulating waveform is 180 degrees.

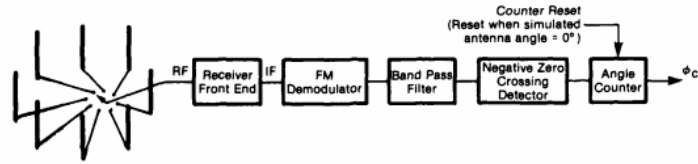
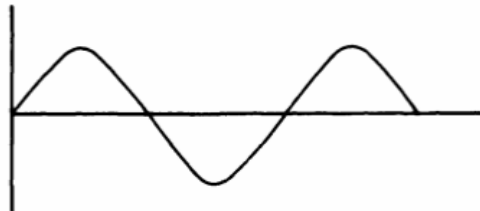
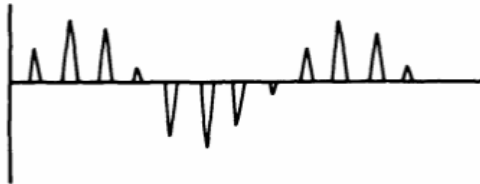

FIGURE 5: Pseudo-Doppler System Block Diagram

A block diagram of a pseudo-Doppler system is shown in **Figure 5**. The sensor system consists of a circular array of dipole antennas connected to an antenna controller. The controller sequentially connects one antenna at a time, to the receiver input. Adjacent antennas are spaced less than one half a wavelength apart to avoid ambiguities in the phase measurements.



(a) FM Demodulated Signal for a Rotating Antenna System



(b) FM Demodulated Signal for a Sampled Antenna System
FIGURE 6

The receiver converts the RF signal to an intermediate frequency suitable for the demodulator. The output of the demodulator is a voltage related to the input frequency of the signal, given by

$$V_0 = k(F_s - F_c)Volts$$

here

V_0 - demodulator output voltage,

k - gain,

F_s - input frequency

F_c - carrier frequency.

Since there are various standard FM demodulators currently in use, and the internal operations of the demodulator are not important to this discussion, the specifics of the demodulator are not discussed here.

If a rotating antenna was used in the sensor system, the output of the demodulator would vary smoothly as shown in Figure 6a. However, since the effect of rotation is simulated by sequentially sampling the outputs of a discrete number of antennas, the demodulator output is actually a series of spikes (Figure 6b). These spikes occur during transitions from one antenna to another resulting in a sudden change in signal phase. Since frequency is a measure of the rate of change of the instantaneous signal phase, this sudden change in phase appears as a sudden apparent change in frequency. A bandpass filter centered at the antenna rotation frequency, smooth out the spikes.

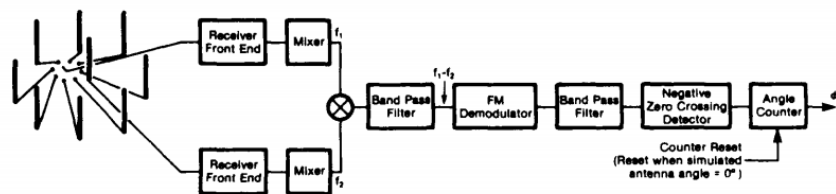

FIGURE 7: Differential Pseudo-Doppler System Block Diagram

From this smoothed waveform, the DF processor determines the negative zero crossing of the signal. The DF processor also keeps track of the angular position of the simulated rotating antenna. The signal bearing angle is the angular position of the simulated antenna with respect to the center of the antenna array at the time of the negative zero crossing. If the equipment adds any phase delays during signal processing, this results in a fixed offset that must be subtracted from the measured bearing.

A variation of the single channel pseudo-Doppler system described above is the differential pseudo-Doppler system shown in Figure 7. This system employs a sense antenna located at the center of the array. The two antenna system outputs (the sampled antenna output and the sense antenna output) are converted to the intermediate frequencies $f1$ and $f2$. The outputs are mixed

followed by filtration to remove the high frequency components $f_1 + f_2$. The rest of the processing from the demodulator onwards is the same as described previously. The advantage of this system is the removal of frequency variations in the RF signal that are not caused by the Doppler rotation. This is important when signals other than CW are considered.

2.11 Main Requirement of RDF Systems

The principle requirements for a radio direction finding system are provided below:

- Accuracy: the accuracy of direction finding systems should be as high as possible. The best working accuracy attained by conventional direction finding systems is of the order of few degrees, which is too imprecise for targeting applications.
- Automation: After installing the system, it should measure the bearing automatically within shortest time.
- Mobility: the direction finding equipment should be mobile, either vehicle mounted or portable
- Short set-up time: Conventional direction finding systems take 10-15min at maximum to remain at any site. Any time longer then this will reduce the usability of the system. Hence, the set-up time should remain less than this time.
- Robustness: the equipment should be robust to withstand rugged and rigorous military environment.

The first requirement is the main principle focus of this design report. The limitations in accuracy as a function of various techniques and implementations are discussed in detail. Some technical difficulties and various measurement criteria to describe performance are also discussed.

The second requirement, automation, constrains CDF systems to fixed antenna arrays. Direction finding techniques that require the antenna to be moved or rotated to determine the direction of arrival of the signal are too slow for modern tactical purposes.

The final three requirements (mobility, short set-up time, and (robustness) limit CDF systems to being small and light enough to be carried by man or vehicle, simple to set up, and reliable.

Chapter 3

Pseudo-Doppler

Direction Finding Method

In Doppler direction finding system, we incorporate the relative motion between transmitter and receiver. The problem arises when the direction finding system is not in motion. This problem is solved by attaching a vertical antenna on a turntable and rotating it with certain frequency. This rotation will create a relative motion between the transmitter and receiver. It uses the variation in the velocity of a signal introduced by the rotating antenna array to induce the Doppler Effect. The bearing is estimated based on measured Doppler shift, which is induced due to relative motion of antenna with respect to incoming wavefronts. The circular motion of the antenna will result in a Doppler sine wave modulation. At nearest and farthest distance from the transmitter (point A and C) the relative motion will be zero which is depicted with zero-crossing of sine wave (figure 4). When the antenna is at position B (moving away) or D (moving towards), the relative Doppler shift is maximum that is depicted by negative or positive peak respectively. The frequency of sine wave is same as the rotational frequency of the rotating antenna.

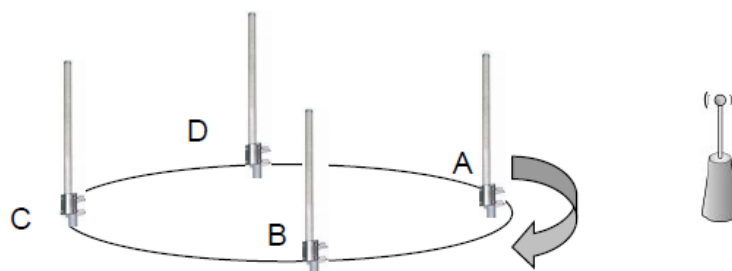

Figure 4 Doppler

Pseudo-Doppler is a direction finding system based on the phase measurement. The original method is based on mechanically rotating antenna (circular rotation) to measure the relative shift in frequency but the contemporary method used the multi-element circular antenna array to simulate the effect of circular rotation. This sequentially switched antenna array is used to avoid the cumbersome caused by the rotation antenna. It sometime becomes practically unfeasible to rotate an antenna with sufficiently high rotational frequency.

Doppler direction finding have gained popularity in inexpensive application especially transmitter/radio hunting due to their simple construction and use. Their simpler understanding and effective operation is attributed to common physics concept of Doppler Shift. This concept is exploited in pseudo-Doppler implementation using a special antenna array that produces artificial motion to simulate Doppler Shift on the received signal. This effect result in Doppler-

modulated (frequency modulated) received signal, which can be processed with a FM demodulator to obtain an audio tone that has quantifiable characteristics, which vary depending on signal direction. Doppler direction finding system measures these characteristics and processes them to determine the signal bearing.

3.1 Doppler Characteristics

In contrast to other direction finding systems, the primary advantage of Doppler direction finding systems is the speed of their display. They have the capability to generate and update the direction finding display almost instantaneously, without any user input. They outperform when locating transmitters with signals of transitory duration due to their instantaneous display update resulting in accelerated localization. They have simpler construction with basic devices, consisting of low-technology audio circuitry and a few basic RF circuits in antenna. They gained popularity in 70s when commercial RF PIN-diodes became available commercially.

These direction-finding systems have impressive characteristic but they have some inherent weaknesses. They use low-gain omnidirectional antennas, which are vulnerable to reflections and multipath effect. The pseudo-Doppler variant of Doppler based direction finder have larger bearing errors in multipath situation due to sampling of electromagnetic field. This larger bearing error is triggered by the existence of aliasing effect. The simulation applications provide dominant ways for insightful research in Doppler direction finding systems and their use. It has been demonstrated that multipath signals result in spread of low-frequency spectrum after the frequency modulator; and when the electromagnetic field is sampled, the low-frequency spectrum append with each multiple of the sample frequency.

Doppler direction finding systems are not preferred to track weak signals, instead direction finder with high-gain antenna are used. They perform upright at high frequencies usually VHF or higher as at lower frequencies the antennas turn out to be large. They can work with various types of signals such as AM, SSB, etc. but the systems itself use an FM receiver and demodulator. The antenna array is usually mounted at the highest possible point to establish a clear and unobstructed view of horizon in all directions, in order to minimize reflection from nearby objects.

Doppler based direction finding systems are not a solution to all scenarios as they sometimes become useless in multipath environment especially if there is no direct path to the transmitter

from the receive antenna system. These scenarios may include populated city areas surrounded by large structures and having orthogonal surfaces and in most indoor cases. They are suited for open environment where clear view of horizon is available. Thus, altitude change of few feet can be of great help to achieve a clear view of horizon.

3.2 Doppler Accuracy

Most direction-finding systems, including Doppler do not mention the bearing accuracy as it is a pretended and misleading quantity. Accuracy of direction finding systems can be realistic only in ideal circumstances as it is degraded by external environment, which is completely beyond the control of direction finding equipment. This environmental degradation inaccuracy cannot be compensated only with technology, no matter how sophisticated it is. There are some basic geometric factors, which make the direction finding very tolerant of errors. In some scenarios where a direction finder is used to focus on a signal, tolerable errors could be very large. For instance, if a tracker follows bearings from a direction finder with an error of 90° , the bearing will lead the tracker around the signal source endlessly.

FIGURE 5 : BEARING ERROR TOLERANCE

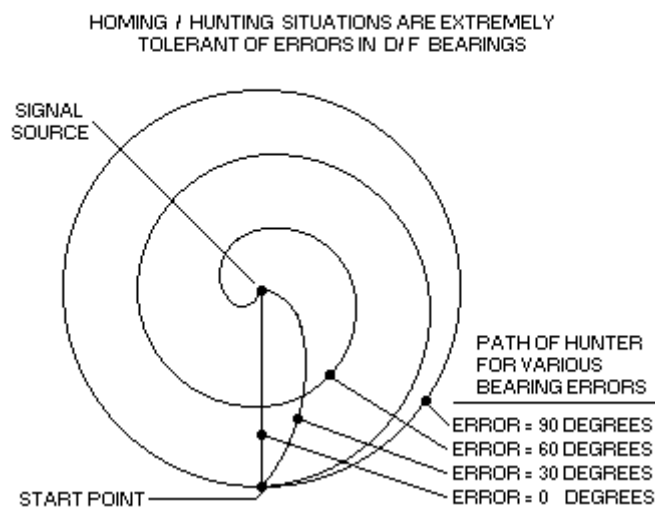

Figure 5 Bearing with 90, 60, 30 and 0 degree of errors.

If the direction finding error is more than 90° , the tracker will slowly moves away from the transmitting source otherwise if the error is less than 90° , the direction finding will lead the tracked towards the source; the same is demonstrated in figure 4. Hence, any direction finding

system with an accuracy of less than 90° will eventually lead the tracker to success. For reasonably small errors (less than 30°) the tracker will travel in somewhat a curved path and hardly notice any error. However, the behavior is assumed for a situation when the signal is continuously observed.

3.3 Doppler Principle

Doppler principle is demonstrated through example Doppler direction finder using eight antenna elements. In most scenarios, only four antenna elements are employed to realize the pseudo-Doppler operation. The direction finder portrayed in example employee eight vertical antenna elements, which are placed on the circumference of a circle; the receiver is sequentially switched to each element for reception. This operation simulates the operation of a single theoretical antenna moving in a circle. The subsequent Doppler shift result in Doppler Modulated received signal, with a sine wave, with frequency equal to the rotational frequency of the theoretical antenna. The same is depicted in figure

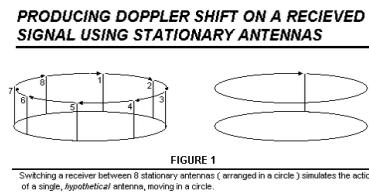

Figure 6 prodigal

The antenna elements must be switched very fast to achieve a significant amount of Doppler shift, say 500Hz at operational frequency of 144MHz. To achieve this amount of Doppler shift the sequential switching frequency f_s is selected as 4.2KHz. Hence, the rotational frequency f_r of the theoretical rotating antenna is calculated as:

$$f_r = \frac{f_s}{8} = \frac{4200\text{Hz}}{8} = 525\text{Hz}$$

The distance between two subsequent antenna elements must be less than the wavelength of operating frequency. Thus, the antenna elements are arranged in a circle with a diameter of two feet (0.61m). These arrangements simulate the movement of a single vertical antenna, which is in circular motion with a tangential speed of 3300 feet per seconds (three times the speed of sound). At 144MHz frequency, tangential speed of 3300 feet per second is equivalent to 500

wavelengths per second resulting in Doppler shift of 500Hz. The switching operation of antenna elements is achieved with diodes to deal with high operational frequency.

Removal of voice modulation is required in direction finder through audio filtering. This will result in construction of Doppler sine wave with reasonable waveform quality. The Doppler sine wave obtained after filtration contains two zero-crossings, one at nearest point from transmitter and the other at the farthest point from transmitter. The nearest point is when the theoretically rotating antenna is at closest distance from the signal source and occurs the termination point of positive half cycle. The farthest point occurs at the termination point of negative half cycle of Doppler sine wave. The detection of the nearest point from the waveform will result in determination of direction, as it will give the antenna position, which is closest to the transmitting source. The same is depicted in figure 6 with positive half-cycle of Doppler sine wave.

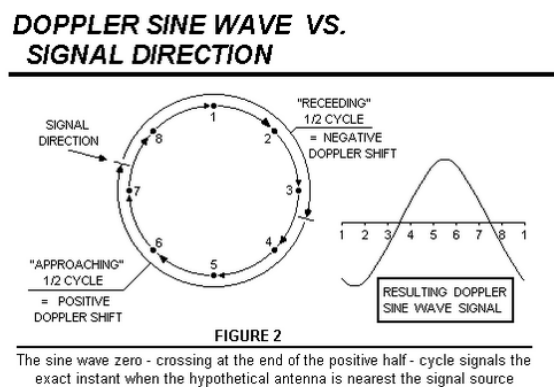

Figure 7 paradoxical

A digital counter is used to track the position of the theoretical antenna at every point and it will serve the purpose of signal bearing counter. The same counter can be used to switch antenna elements and to track the signal bearing with the switching and number in the bearing counter are synchronized.

At the falling edge (zero crossing) of Doppler sine wave, a trigger pulse is produced. This pulse will initiate a latch to capture the binary number in the bearing counter at the exact instant. This captured binary number will be subsequently used to derive a bearing display, which is usually a circle of LEDs. Block diagram of such direction finder circuit is provided in figure 7.

DOPPLER D/F DIAGRAM

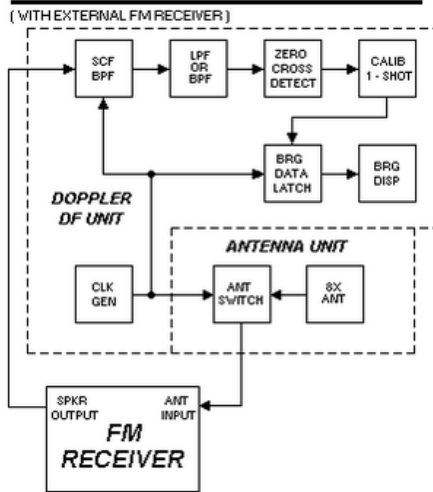

Figure 8 Doppler DF diagram

Doppler modulation is a type of frequency modulation (FM) caused by relative motion of receiver with transmitter. An FM receiver can be used to detect this Doppler frequency modulation. The Doppler modulation in this scenario is a sine wave in audio frequency range; hence, it will pass easily through the audio amplifier of an FM receiver. The direction finder display unit directly from the speaker jack of the FM radio will sample this wave. There is no need of hardware modification of the FM radio.

3.4 The Doppler Sine Wave

The Doppler sine wave produced by eight stationary antenna elements is not the same as produced from single circling antenna. The Doppler modulated sine wave produced from single circling antenna is a true sine wave with good waveform qualities. This type of circling antenna is not used and is replaced by switching antenna element system. This eight element switching antenna element system will actually produce a series of Doppler sine wave pulses. Careful filtering of these pulses will synthesize a reasonable Doppler sine wave. The filter must be equitably sharp to reduce the superimposition of voice modulations.

Practically Doppler direction-finder use a switched capacitor filter (SCF) followed by bandpass or lowpass filters to yield a Doppler sine wave with reasonable quality. The zero-crossing detector circuit use the sine wave generated through filtration to produce bearing count. A

regulating 1-shot is used to calibrate the counter and remove residual errors. The display is derived with the data latch triggered from the output of calibrated output from 1-shot.

Switched capacitor filters (SCF) are simple in construction with interesting qualities, which make them suitable choice for this scenario. Their behavior is like resonant bandpass filter but unlike others; they need an external clock for operation. The clock of SCF decides the center frequency of filter. The SCF is derived by the same clock, which derives the antenna switching to ensure synchronization between center frequency of SCF and Doppler pulses. This process facilitates very narrow bandwidth filter design, typically less than 1Hz, for rejection of voice audio signal.

The microcomputer doesn't use bandpass or lowpass filter, rather it use a switched capacitor filter (SCF). The electrostatic charge that accumulate on the SCF capacitor create a potential difference which is directly measured by the microcomputer. This measured potential difference is used to calculate the bearing using trigonometric principles. This microcomputer programs are very complex and sophisticate but they reduce the overall cost by simplifying circuit.

3.5 Doppler Pulse Principles

This section delivers some insight about Doppler pulses. It describes their polarity, amplitude, duration, shape, and their dependence on antenna spacing, signal direction and receiver characteristics. Some methods for Doppler pulses processing are provided, this processing delivers some meaningful information about signal bearing.

3.5.1 Background

As discussed earlier, Doppler shift is a shift in received signal frequency instigated by relative motion between a receiver and a signal source. Positive Doppler shift occurs when the signal source and receiver are approaching each other and result in increase of received frequency. Negative Doppler shift occurs when the signal source and receiver are receding from each other and result in decrease of received frequency.

The amount of Doppler shift, represented in Hz, is proportionate to the carrier frequency and the relative frequency between signal source and receiver. By representing velocity units in terms of signal units, wavelength per seconds, the Doppler shift will equate directly to the velocity, as both the measures are equal. A transmitting signal source and receiver,

which are approaching with a rate of 500 wavelength per second, will cause 500Hz of positive Doppler shift.

3.5.2 An Example

The working principle of all Doppler based direction finding systems can be demonstrated with two antennas as depicted in figure 9. The motion of a single theoretical antenna, which is moving back and forth between two positions, is simulated by switching between two fixed antennas.

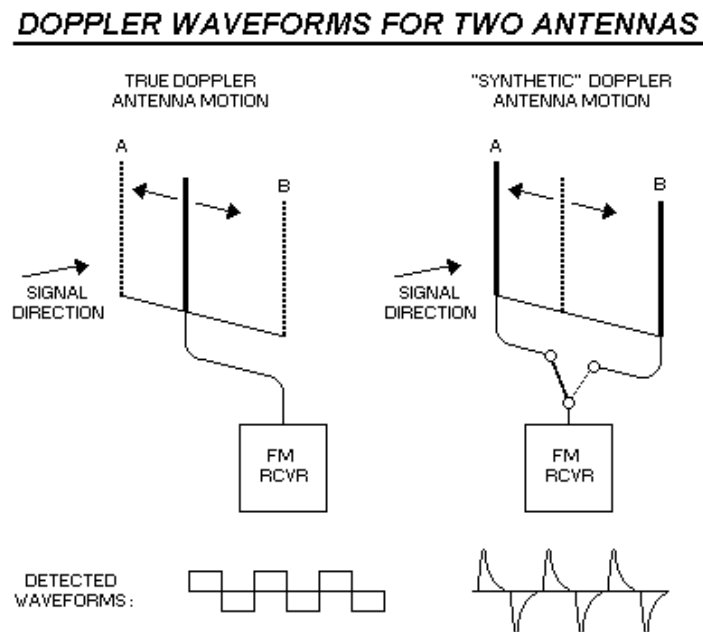

Figure 9 Doppler Waveform

If the theoretical antenna is moving with a constant angular velocity, the resulting Doppler shift modulated as FM will be detected as square-wave signal. The positive half cycle of the square wave will occur when the antenna is approaching the signal source and the negative half cycle of the square wave will occur when the antenna is receding the signal source.

However, the switching between stationary antennas does not simulate constant angular velocity but it simulates antenna motion. As the antenna moves suddenly between two positions, hence the resulting Doppler shift also results in sudden Doppler pulses. The positive and negative pulses generated this way resembles the square wave as the positive

pulse is generated at the position which is nearest the signal source and negative pulse is generated at the position which is farthest from the signal source.

Doppler pulses as depicted in figure 10 cause the phase difference between the two antenna signals, this signal at antenna A arrives slightly earlier than it arrives at antenna B.

It occurs because antenna A is slightly closer to the signal source than the antenna B so it requires slightly less time for the wavefront to approach antenna A. If the antenna A is $\frac{1}{4}$ wavelength closer to the source, the resulting phase difference will be 90°.

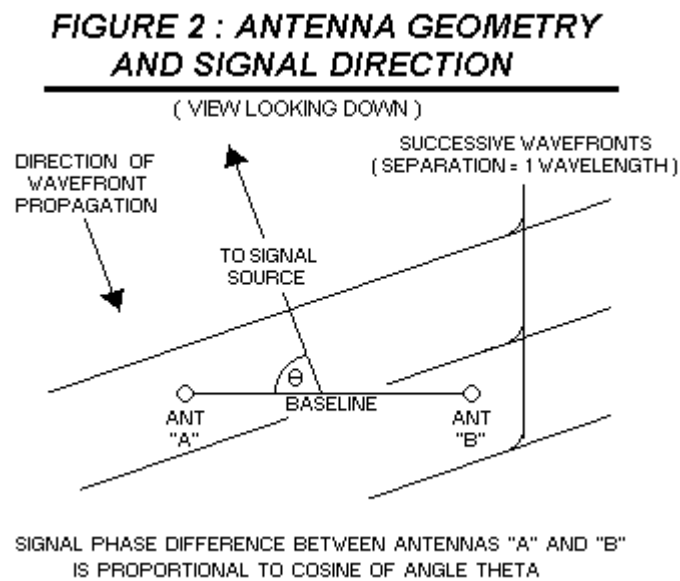

Figure 10 Signal Direction

The resonant circuits of the receivers RF and IF amplifiers will be altered to the changed signal phase if the input of the FM receiver is switched between antennas due to derivation of these signals from the RF source. The amount of phase change in RF and IF amplifiers is equivalent to the amount change at the antennas. In this case, Doppler pulses are produced as a side effect during the readjustment process.

The amount of change in phase in the antennas is proportional to the cosine angle made by the baseline connecting the two antennas and the signal direction. Minimum phase shift of zero degrees occurs when the signal approaches from perpendicular direction to the antenna baseline and maximum phase shift will occur when the signal approaches from a direction, which is parallel to the antenna baseline. This maximum phase shift is limited by the

separation between the antennas and is expressed in terms of wavelengths with 1 wavelength equaling 3600.

3.6 Bearing Ambiguities

When only a single antenna pair is considered, Doppler pulses of equal magnitude will be formed by signals arriving at the antenna pair from any four possible directions, the same is depicted in figure 11. The cosine measure for these four signal directions is identical. A synchronous audio detector can be used for Doppler pulse polarity determination, which can reduce the directions to two possibility. This way, the antenna farthest to the signal source will produce negative Doppler pulses and the antenna, which is nearest, will produce positive pulses. Still there will be two possible signal direction when we are incorporating audio synchronous detector so at least two antenna pairs are necessary for unique signal direction.

**FIGURE 3 : BEARING AMBIGUITIES
WITH A SINGLE ANTENNA PAIR**

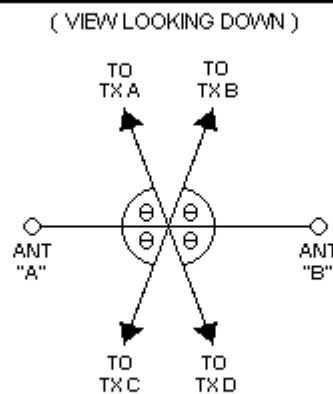

ANGLE THETA IS IDENTICAL FOR SIGNALS APPROACHING
FROM ANY OF FOUR DIFFERENT DIRECTIONS

Figure 11 Bearing ambiguities

3.7 Doppler Pulse Waveforms

The amplitude, duration and shape of Doppler pulses are determined by the receiver passband characteristics which is determined predominantly by the IF filters. It is hard to determine the value of these parameters for a particular signal without knowing the detailed information about the filters used in IF amplifiers and a substantial amount of mathematical calculation. Another

approach is to measure the response using some sophisticated and expensive equipment. Despite this, some generalizations can be established:

- A narrowband IF amplifier will produce Doppler pulses with longer duration and lower amplitude.
- A wideband IF amplifier will produce Doppler pulses with shorter duration and higher amplitude.
- The peak in Doppler shift will occur at the leading edge of the Doppler pulse and will gradually reduce.
- The total area of the pulse will remain proportionate to the phase shift of RF signal, which occurred during antenna switching. Following section provides the detail of this occurring:

As a basic rule of thumb, the impulse response of a narrowband amplifier is equal to the inverse of the amplifier's bandwidth. For example, an amplifier with 1 kHz bandwidth will take 1ms to become stable after change in input signal state whereas an amplifier with 10 kHz bandwidth will take 0.1ms to achieve the same state. If the IF bandwidth of an FM receiver is meaningfully broader than the FM detector bandwidth, i.e. wider than the linear detection range, it can be erroneous. The FM detector due to its bandwidth limitations will discard part of the Doppler pulse and it will not detect the Doppler waveform faithfully.

3.8 Doppler Pulse Energy

Doppler modulation, which is caused by relative motion between signal source and receiver, is a type of frequency modulation (FM). An FM receiver is therefore required for detection of Doppler modulation. The amplitude of Doppler pulses provided by FM detector is insignificant as the area enclosed by the pulse, representing the pulse energy. The area enclosed by the pulse signify the signal energy which is directly proportional to the amount of phase shift occurred during antenna switching. This phase shift is proportionate to the cosine of bearing.

A rectangular Doppler pulse is depicted in figure 12 with a pulse duration of 0.5ms and an amplitude of 500Hz. The area enclosed by the pulse can be calculated by multiplying the height with the base of pulse;

$$Area\ of\ Pulse = 0.0005s \times 500 \frac{cycles}{seconds} = 0.25\ cycles = 0.25\ cycles$$

This area of the pulse is 0.25 cycles, which equals 90° or $\frac{1}{4}$ wavelength. This indicates that the antenna which created this pulse is quarter wavelength closer to the signal source than the other antenna.

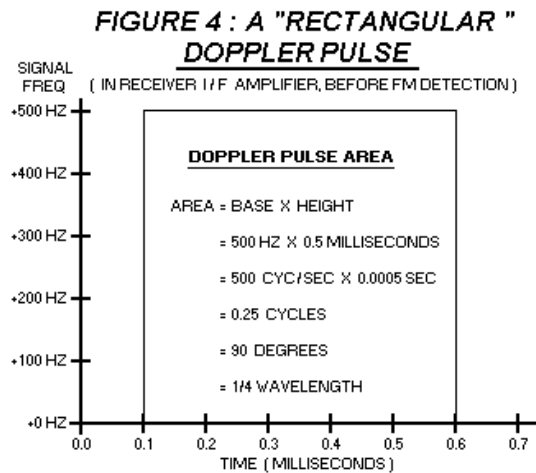

Figure 12 Rectangular Doppler pulse

3.9 Doppler Pulse Integration

FM detectors are frequency to voltage converters. Detector coefficient, expressed in $\frac{V}{Hz}$ is used to characterize the behavior of FM detectors. It can be multiplied with pulse area to estimate the pulse area estimation. The pulse area after FM detection will be expressed in terms of *volts-second* as the pre-detection pulse area is expressed in *hertz-second* and detector coefficient is expressed in $\frac{V}{Hz}$. Therefore, required circuitry should translate the *volts-seconds* signal into *volts* signal so the resulting voltage signal can be used to represent the cosine of the signal angle.

This task can be done by using an integrated circuit. An Integrator circuit produces an output that is proportionate to area of the input pulse. The term integrator is derived from integration, which refers to a mathematical function that calculates the area under the curve. The pulse waveform is substituted with curve and the integrator circuit performs integration and provides the area under the waveform.

A switched capacitor filter (SCF) is used to perform integration in Doppler direction finder. This SCF consist of RC-integrator circuits and an individual integrator circuits are attached to

$$\frac{\text{output}}{\text{input}} = \frac{\text{volt} - \text{seconds}}{\text{volt}}$$

each antenna that are sequentially derived to obtain an integrated waveform (pulse area). As the output signal of FM detector is represented with detector coefficient, the output signal of SCF integrator is represented as integration coefficient. As the input to an integrator is represented with *volts-seconds* and the output is represented with *volts*, so the output of integrator will be represented as $\frac{1}{\text{seconds}}$ due to the expression;

Multiplying this coefficient with Doppler pulse area, output voltage of integrator will be obtained. It will be proportionate to the cosine of the angle of signal direction as observed on antenna array.

3.10 DOPPLER DATA PRESENTATION

By using four antenna elements (two antenna pairs) and orthogonally orienting the baseline of two pairs, one antenna pair can be used for cosine of the signal direction and the other as a sine of the signal direction. Instead of actual measurement of these parameters, they can be compared to each other's for signal direction indication ($\frac{\text{sine}}{\text{cosine}} = \text{tangent}$). The circuit in figure 13 depicts an example of its implementation using a regular magnetic compass indicator.

A Simple "Resolver" Doppler DF

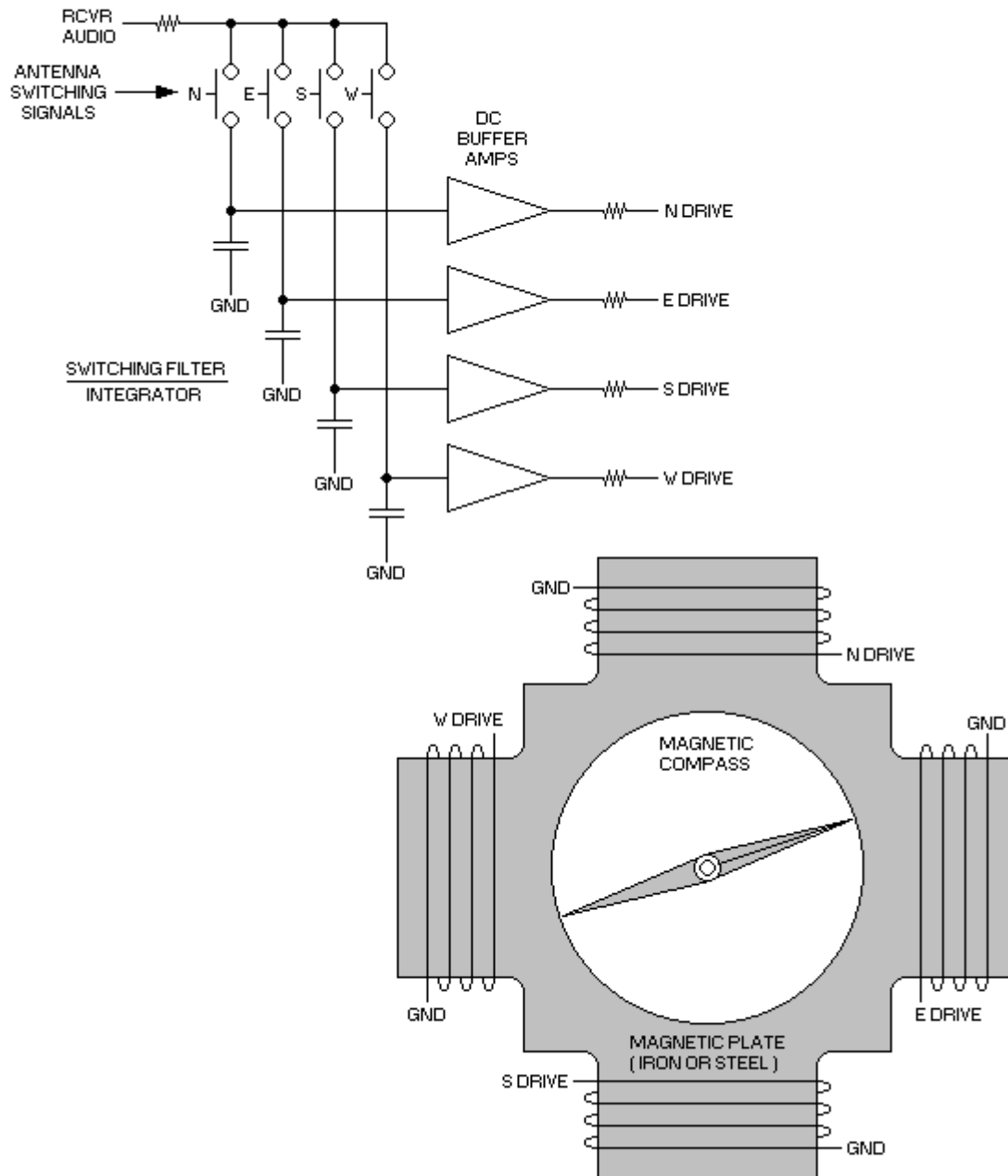

Figure 13 DF Resolver

3.11 Pseudo-Doppler Antenna Phase Delay

In pseudo-Doppler direction finding system, an n-element antenna array, which is uniformly distributed over the circumference of a circle, is used. It is pointed out that periodically sampling antennas in pseudo-Doppler direction-finding (DF) systems create numerous sidebands above and below the receiving carrier. When sidebands of multiple incoming signals interfere with one another, false readings often result. As the receiver samples antennas, the process modulates the incoming signal's amplitude. In such DF systems, square-wave AM radically widens the detected signal's frequency span. Ways of reducing the bandwidth of the sampled signals are briefly discussed. Advantages and disadvantages of implementing pseudo-Doppler systems over other DF systems are weighed. It is concluded that pseudo-Doppler DFs should be considered only when the system's cost or complexity must be limited and the detected signals are not in a crowded portion of the RF spectrum.

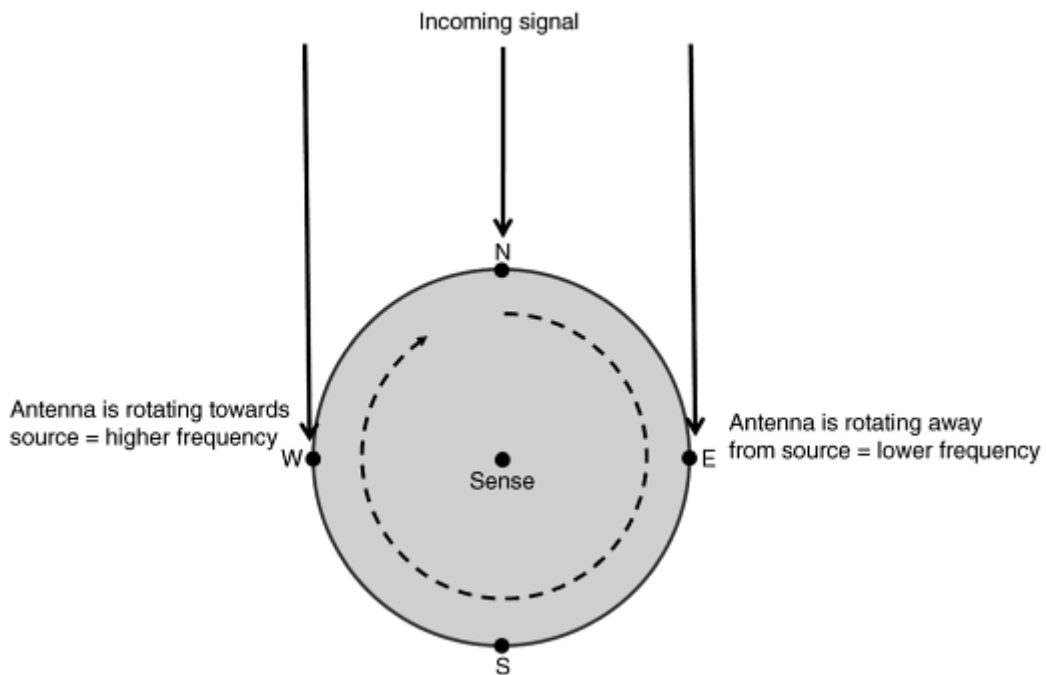

Figure 14 the figure shows a four-element pseudo-Doppler direction finding system. Each of the antenna will be turned on an off in N-E-S-W sequence.

Chapter 4

Comparison of Single- Channel Direction Finding Techniques

This chapter provides comparative analysis of single channel direction finding techniques. Some of these techniques are discussed briefly in chapter 2. Chapter 3 describes the detail of two single channel direction finding techniques; true Doppler and pseudo-Doppler. Pseudo-Doppler is an enhanced and more practical implementation of true Doppler. The pseudo-Doppler direction finding method has some limitation over true Doppler in respect of performance. These limitations are overcome by the rotation free mechanism of true Doppler, which made it impractical in some scenarios. Watson-watt method, which is implemented using Adcock antenna design is an amplitude-based direction finding technique opposed to Doppler, based technique that are principally phase based methods but their amplitude based implementation is also used with Phase-locked loop.

The two techniques that are scrutinized for single channel direction finding are the Adcock antenna array based Watson-Watt technique and circularly switching pseudo-Doppler techniques [6x, 7x]. Watson-Watt technique is an analog receiver based low frequency operating techniques, which is usually operated up to 1000MHz. The pseudo-Doppler technique is implemented as a conventional phase based and a contemporary amplitude based direction-finding method.

4.1 Watson-Watt Method

Watson-watt is a single-channel amplitude-based direction finding method, which use the amplitude of signal received from two antenna arrays for relative comparison. These two antenna arrays are arranged according to Adcock design, which consist of four elements in a crossed-baseline, perpendicular configuration as in figure x.

This direction finding method is typically used for frequencies up to 1000MHz. single pair of Adcock array contains two antenna arrays, four antenna elements as a whole, which are arranged in perpendicular fashion. These antenna elements can be crossed dipole, crossed monopole, crossed loops or crossed-ferrite loop. The spacing between two adjacent antenna elements is kept less than half of the wavelength at highest operational frequency. Each of two antenna elements of an array is used to obtain the azimuth gain pattern. The four signals obtained from each antenna elements labelled; North, South, East and West, in complex baseband notation are:

$$r_{North}(t) = m(t)e^{j\frac{2\pi R}{\lambda}} \sin(\varphi)$$

$$r_{South}(t) = m(t)e^{-j\frac{2\pi R}{\lambda}} \sin(\varphi)$$

$$r_{East}(t) = m(t)e^{j\frac{2\pi R}{\lambda}} \cos(\varphi)$$

$$r_{West}(t) = m(t)e^{-j\frac{2\pi R}{\lambda}} \cos(\varphi)$$

Here;

$r(t)$ =Received signal,

R =Radius of the circular array

λ =Wavelength of frequency of interest

$m(t)$ =Message signal $x(t) = r_{North}(t) - r_{South}(t) = 2m(t)$

φ =Angle of arrival $y(t) = r_{north}(t) - r_{south}(t) = 0$

East antenna represents zero degree reference. [6x]

The East-West antenna pair generates the x-axis voltage. It has maximum gain when $\varphi = 0^0$, the signal strength in north and south antenna are equal. In this case;

$$x(t) = r_{East}(t) - r_{West}(t) = 2m(t)$$

$$y(t) = r_{East}(t) - r_{West}(t) = 0$$

The North-South antenna pair generates the y-axis voltage, which produce maximum gain along y-axis. East-West signals become equal when $\varphi = 90^0$ thus;

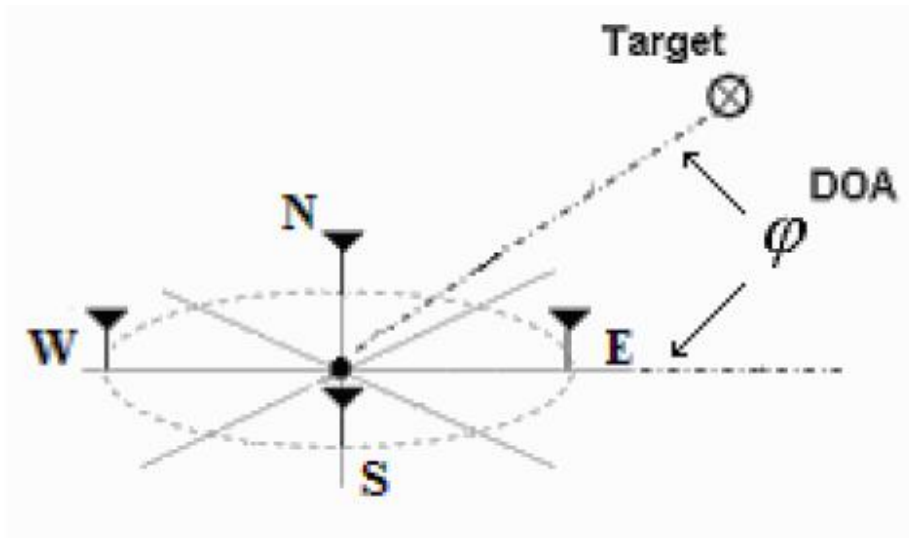

Figure 15 Adcock Antenna Array used for Watson-Watt Algorithm

A composite signal is formed by combining each x and y-axis voltages to pass the angle of arrival data to the single receiver circuit. The composite signal is a linear combination to form an AM signal with dual tone modulation the AM receiver takes the AM composite signal and perform demodulation, the estimated bearing is calculated by the following formula.

$$y(t) = r_{north-south}(t) = 2j * m(t) \sin\left(\frac{2\pi R}{\lambda} \sin(\varphi)\right)$$

$$x(t) = r_{east-west}(t) = 2j * m(t) \sin\left(\frac{2\pi R}{\lambda} \cos(\varphi)\right)$$

$$\hat{\varphi}(t) = \arctan\left(\frac{y(t)}{x(t)}\right)$$

$$= \arctan\left(\frac{2j * m(t) \sin\left(\frac{2\pi R}{\lambda} \sin(\varphi)\right)}{2j * m(t) \sin\left(\frac{2\pi R}{\lambda} \cos(\varphi)\right)}\right)$$

$$= \arctan\left(\frac{\sin\left(\frac{2\pi R}{\lambda} \sin(\varphi)\right)}{\sin\left(\frac{2\pi R}{\lambda} \cos(\varphi)\right)}\right)$$

$$= \left(\frac{\sin(\varphi)}{\cos(\varphi)}\right)$$

The approximation in the above equation is true for small values of $\frac{2\pi R}{\lambda}$ as $\sin(x) \approx x$ for small values of x [6x]. For antenna array of figure 10, an 1800 phase ambiguity will be faced as a positive ratio will represent either quadrant 1 or 3 and a negative ratio will represent quadrant 2 or 4. This 1800 phase ambiguity can be eliminated by introducing a centrally located omnidirectional antenna, which will serve the purpose of directional sensing [8x]. next section provides accuracy checking of Watson-Watt algorithm through simulation using an Adcock antenna configuration in various conditions.

4.2 Advantages and Disadvantages of Watson-Watt System

4.2.1 Advantages

Advantages of Watson-watt direction finding system are listed below.

- Availability of low-cost and wide-frequency receivers has realized the compatibility in standalone direction finder and low-cost receivers.
- Suitably designed Watson-Watt direction finder can be interfaced with practically any receiver with high-quality results [8x].
- Diameter of Adcock antenna array is of smaller magnitude, therefore it is preferred in transportable and mobile direction finders.
- Due to AM tone modulation of direction finder, AM rejection of most FM limiters facilitate excellent FM listen-through.
- Listen-through capability for AM signals is good due to lower direction-finder antenna modulation frequencies than the voice spectrum [8].
- Watson-Watt system is especially suitable for mobile applications where there are budgetary constraints.

4.2.2 Disadvantages

The disadvantages associated with Watson-Watt direction finding system are listed below:

- The Adcock antenna array has narrow aperture so the resolution of direction finder is affected.
- A 180⁰ phase ambiguity is faced if the omnidirectional center antenna is not used.
- Due to its narrow aperture, Watson-Watt system is prone to reflection errors and multipath effect.

- The Adcock requires well-adjusted sum and difference pairs, modulators, cables with matching phase and circuits for gain or phase disproportion. Cost of the array will escalate due to all these complexities [7x].
- Maximum frequency is limited in Watson-Watt method due to requirement of complex circuitry for Adcock antenna. A wideband direction finding system is not feasible so this method cannot be used for frequencies over 1000MHz [8x].
- Watson-Watt method does not provide elevation measurement. It has greater influence over the azimuth at high frequencies.

4.3 Advantages and Disadvantages of Pseudo-Doppler System

4.3.1 Advantages

The advantages of pseudo-Doppler system over Watson-Watt direction finder are listed below:

- Pseudo-Doppler have advantage of site error suppression, economical direction finding antenna and high frequency performance.
- Circular arrangement of antenna array elements, the array is built as wide aperture array.
- Due to wide aperture array implementation, angle of arrival resolution is increased and site errors are reduced. However, increase in number of elements can result in complexity and increased size.
- Due to $\frac{\lambda}{2}$ as constraint between adjacent antenna elements, increase in number of elements will result in increased size and difficult mobility [8x].
- The circuitry of pseudo-Doppler system consists of high frequency RF switches made with GaAs FETs and phase matched cables, driver circuitry [7x].
- A narrow aperture pseudo-Doppler direction finding antenna array is easy to construct and is economical when compared to Watson-Watt system. Increasing aperture will increase the cost and complexity of the design but they will remain less expensive than Adcock array [8x].
- Pseudo-Doppler can work at frequencies up to 2000MHz and more due to its simpler circuitry and ease of wideband design. This will broaden the range of applications such as cellular applications [8x].

4.3.2 Disadvantages

The disadvantages associated with pseudo-Doppler system are listed below:

- Wide aperture pseudo-Doppler system can suppress site errors but the larger size will limit the mobility and concealment.
- The quality of receive circuit needs to be more complex as the pseudo-Doppler require more sensitivity over Watson-Watt system.
- It also requires control of switching circuit so the commutation will choose the correct antenna element.
- The listen-through capability of pseudo-Doppler is also a problem.
- Higher commutative switching rate is required to obtain better accuracy of angle of arrival determination.
- Higher commutation rate lies in audio frequency range and FM audio quality will be badly distorted due to modulation of commutation noise. AM also suffers from consequence of soft commutation switches [8x].

References

1. Peavey, D. and T. Ogumfunmi. *The single channel interferometer using a pseudo-doppler direction finding system*. in *Acoustics, Speech, and Signal Processing, 1997. ICASSP-97., 1997 IEEE International Conference on*. 1997. IEEE.
2. Keaveny, J.J., *Analysis and Implementation of a Novel Single Channel Direction Finding Algorithm on a Software Radio Platform*. 2005.
3. Balanis, C.A., *Antenna theory: analysis and design*2012: John Wiley & Sons.
4. Harrington, R.F., *Time-harmonic electromagnetic fields*. 1961.
5. Grabau, R. and K. Pfaff, *Funkpeiltechnik*. Stuttgart: Franckh'sche Verlagshandlung, W. Keller & Co, 1989: p. 350-351.
6. Hopkins, H. and F. Horner, *Direction-finding site errors at very high frequencies*. Proceedings of the IEE-Part III: Radio and Communication Engineering, 1949. **96**(42): p. 321-332.
7. Ksienski, A. *A Survey of Signal Processing Arrays*. in *AGARD Conference, Proceedings on Signal Processing Arrays*. July 1966.
8. McLeish, C. and N. Burtnyk, *The application of the interferometer to hf direction-finding*. Proceedings of the IEE-Part B: Electronic and Communication Engineering, 1961. **108**(41): p. 495-499.
9. Burke, B.F. and F. Graham-Smith, *An introduction to radio astronomy*2010: Cambridge University Press.