

Passive Infrared (PIR) Sensor Based Security System

Pema Chodon, Devi Maya Adhikari, Gopal Chandra Nepal, Rajen Biswa, Sangay Gyeltshen, Chencho
Department of Electronics and Communication, College of Science and Technology, Royal University of Bhutan,
Phuentsholing, Bhutan

Abstract—In this paper, a PIR based security system which saves the power consumption and the memory space of the recording system has been proposed. Passive Infrared Radiation (PIR) sensor detects the change in infrared radiation of warm blooded moving object in its detection range. According to the change in infrared radiation, there will be a change in the voltages generated which was amplified and used to turn ON the webcam and lighting system through relay. Software was developed and installed in the computer to capture and record the video when the webcam gets turned ON. When an intruder comes in the detection range of the PIR sensor, it actuates the lighting system and the webcam. The software detects the webcam connection; it will start to record and save the video. Once the intruder moves out of detection range of the sensor, the webcam and light gets turn OFF. The software repeats the process. Thus the saves power consumption and the memory space of the recording system as the lamp and webcam will only get turned ON when PIR sensors detects an object. Consequently the system starts recording only when the webcam is turned ON; hence saving memory space.

Keywords— PIR sensor, webcam, lighting system, recording system.

I. INTRODUCTION

Due to increasing number of crime and burglary, the need of security system is very essential. The security system that monitors the area throughout the time and reacts effective to the treat is in need. We have lots of security systems in the market for both indoor and outdoor applications such as ultrasonic detectors, CCTV, microwave detectors, photoelectric detectors, infrared detectors etc. [1]. However one or the other systems have the limitations of being expensive, more electrical power consumption, more memory space utilization of the recording system and complex circuitry, etc.

A solution to overcome these problems could be by using a sensor of low cost which has the ability to detect the intruders as they come within the sensor's detection range and generates an output. This output can be used for further signal processing or activating other devices like alarm system, lighting system, recording system and similar devices. This could at least save some power consumptions as some components get actuated only when there are intruders in the sensors detection range. Passive Infrared Sensor is a low cost, low power and reliable sensor [2]. Therefore it was felt that a PIR sensor based security system consisting of the sensor, a lighting system and a recording system (webcam and the software for saving the video) could overcome few or all of the above stated problems. The sensor can detect the presence

II. SYSTEM DESIGN

of intruders. Upon detection of IR, PIR sensor generates the output in the form of electrical signal. Although the output from the sensor is of few volts, it could be amplified to required voltage using amplifier circuit and could be used for actuating lighting system and the webcam. The lamp and webcam could be turned ON when the PIR sensor is activated and could remain OFF when the sensor is idle. This way, the energy consumed by the overall system could be minimised. Also the cost of system could be far less than the security system available in the market. With this hypothesis, we have proposed a simple low power PIR based security system. It consists of connecting lighting system and webcam to the PIR sensor and software development for the recording video captured by webcam on the computer.

The system works in the following steps:

- i. The software developed is kept running and checks if the webcam is turned ON.
- ii. When an intruder comes in the detection range of the PIR sensor, the sensor generates an output of 3.3 volts.
- iii. This output is further amplified and is used for activating the relay of the lighting system and the webcam.
- iv. Once the lamp and webcam are actuated with the output from the amplifier, software finds the webcam is turned ON.
- v. The software starts to save the video captured by the webcam on the computer.
- vi. After the intruder leaves the detection range of the sensor, there is no output from the sensor. Therefore, it turns OFF the lamp and the webcam. The video captured will be saved in the computer.
- vii. Every time when the intruders come in the detection range of the sensor, the above steps from step 2 to step 6 repeats.

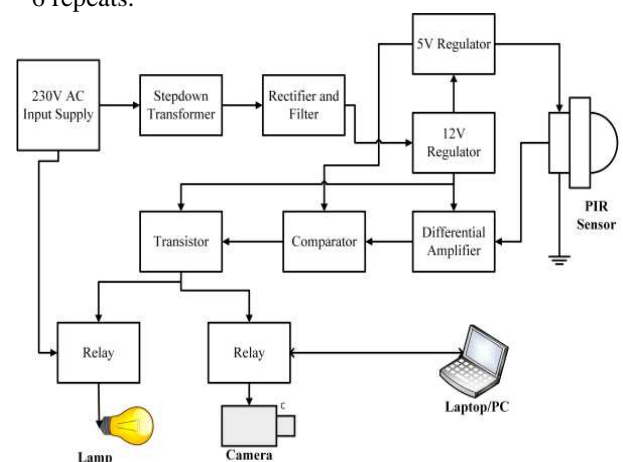

Fig. 1 Block diagram representation of the proposed security system

The proposed system basically consists of two parts viz. hardware part and software. These two parts are interfaced to

work with each other according to the response of the PIR sensor.

A. Hardware parts

The hardware part consists of PIR sensor, power supply, amplifier, window detection circuit, webcam and the computer.

1) *PIR Sensor:* The PIR sensor is the core part of the system. The system basically function based on infrared radiation, which is emitted from human body [3]. PIR sensor is widely used in security system to detect the motion of human [4]. Infrared (IR) light is electromagnetic radiation with a wavelength between 0.7 and 300 micrometres. Human beings are the source of infrared radiation. It was found that the normal human body temperature radiate IR at wavelengths of 10 micrometre to 12 micrometre [5][6].



Fig. 2 Infrared Radiation of human body

PIR sensors are passive electronic devices which detect motion by sensing infrared fluctuations [7]. It has three pins (gate, drain and source). After it has detected IR radiation difference, a high is sent to the signal pin.

PIR sensor is made up of crystalline material that generates a surface electric charge when exposed to heat in the form of

IR [5]. This change in radiation striking the crystalline surface gives to change in charge. The sensor elements are sensitive to radiation of wide range but due to the use of filter window that limits the sensitiveness to the range 8 to 14 micrometre which is most suitable to human body radiation [5].

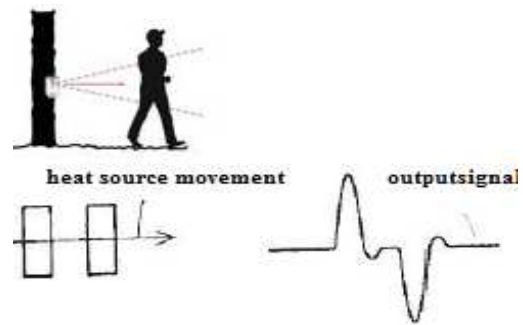

Fig. 3 Working of PIR sensor



Fig. 4 A typical PIR sensor

2) *Power supply:* The power supply circuit involves the conversion of 230 volts, 50Hz AC into 16 volts DC. This is achieved by using step down 16-0-16 centre tapped transformer full wave rectifiers. The AC ripples are eliminated using the passive filter i.e. capacitor. The Fig. 5 shows the circuit for the power supply.

Fig. 5 Power supply circuits for 12V regulator and 5V regulator

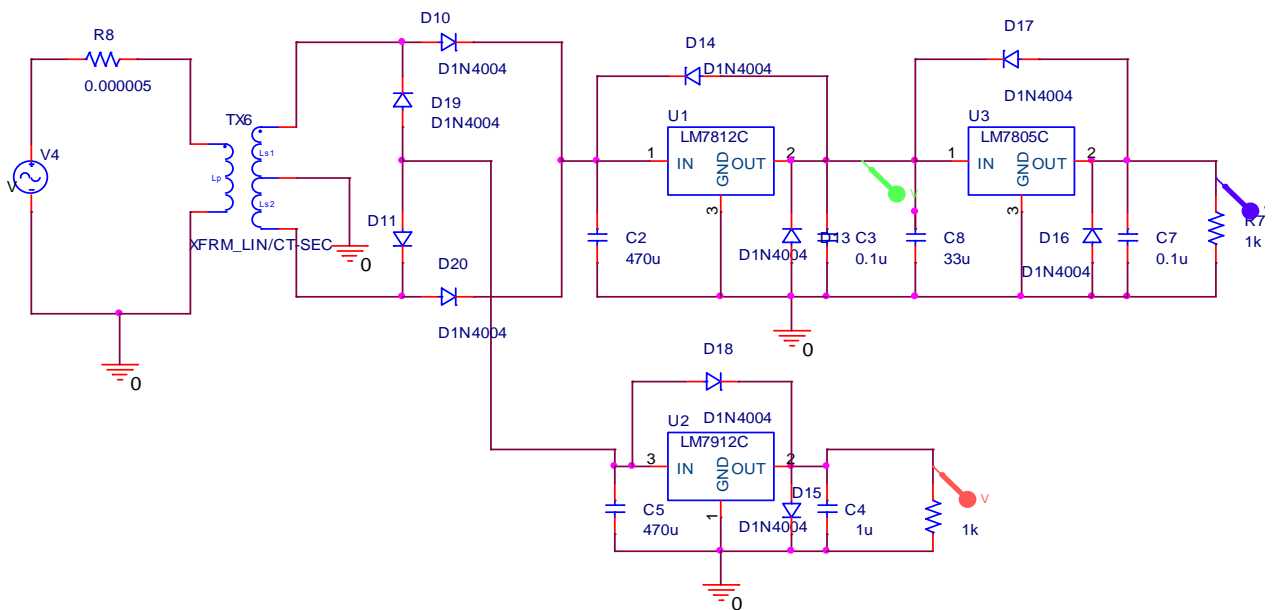

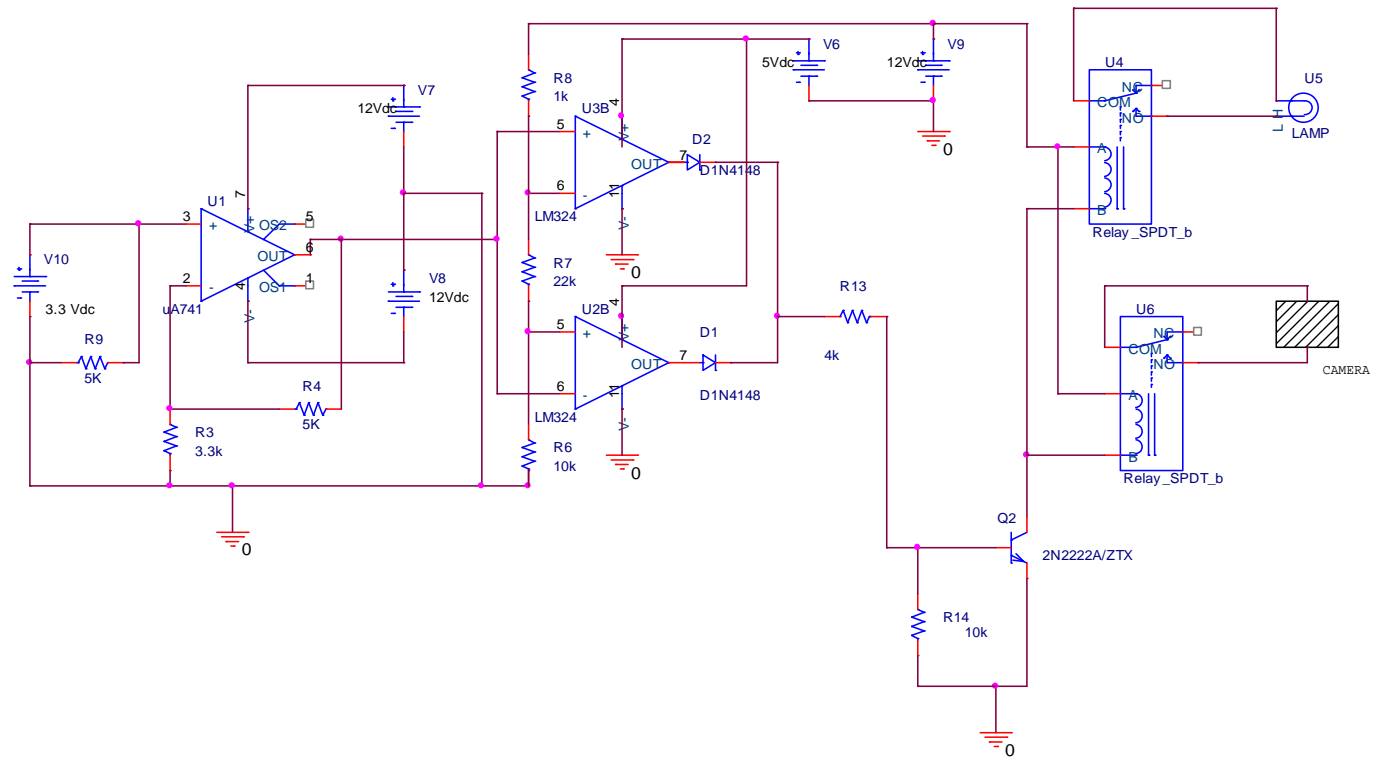

Fig. 5 Complete circuit diagram of the system

3) *Differential amplifier and window comparator:* A differential amplifier has been used to amplify the output from the PIR sensor. The output of PIR sensor i.e. 3.3 volts is amplified to 5 volts. This voltage when supplied to window comparator is compared with the two references voltage inputs at window comparator. Thus, as per the response of the PIR sensor the diodes D1 and D2 shown in Fig. 6, will be forward or reverse biased: controlling the input to the transistor. This output from the window comparator controls the base current at the transistor that acts as a switch for the regulation of the voltage flow to the relay of lights and webcam.

4) *Webcam and Lighting System:* The webcam will be used to capture the scene when the intruder has entered the detection range of the PIR sensor. The relay after the transistor switch will act as a switch to complete the power supply to lighting system and the webcam. When the PIR sensor is activated by the intruder in its range, the webcam and the lights gets turned ON. The software automatically records the scene and saves for future reference. When the intruder leaves the detection range, the lights and the webcam gets turns OFF.

In Fig. 6, 3.3V supply represents the PIR sensor when it is activated. The 5V and 12V represents the voltage supply from the regulators. The lamp and the webcam get turned ON when the PIR sensor is activated.

B. Software

1) The software program is developed based on Microsoft Visual C++ 2010 integrating with OpenCV 2.4.4 library files. OpenCV library files allows Generic image/video loading, saving, and acquisition which is backbone of this program [8]. Following libraries were used:

- opencv_core244.lib
- opencv_imgproc244.lib
- opencv_highgui244.lib

- opencv_ml244.lib
- opencv_video244.lib
- opencv_features2d244.lib
- opencv_calib3d244.lib
- opencv_objdetect244.lib
- opencv_contrib244.lib
- opencv_legacy244.lib
- opencv_flann244.lib

C++ is regarded as a middle-level language, as it comprises a combination of both high-level and low-level language features [9].

Software is kept running all the time. It continuously checks if the webcam is ON. Turning ON and OFF of the webcam is controlled by the output of PIR sensor; webcam gets turned ON only when PIR sensor detects the intruder. The program detects that the webcam is turned ON and starts recording the video captured by webcam in the computer. When the intruder leaves detection area of the sensor, webcam gets turned OFF. The program saves the recorded video and it again continuously checks whether the webcam is ON or not.

2) *Algorithm:* The program is written based on the following algorithm. The program executes in the following steps:

1. Start the program
2. Check if the webcam is ON
3. If the webcam is ON, start recording the video until the webcam turns OFF
4. Else Continue to check if the webcam is ON
5. Then loop the process from 3 to 4.

3) *Flow Chart:* The flow chart for the above algorithm is as follows:

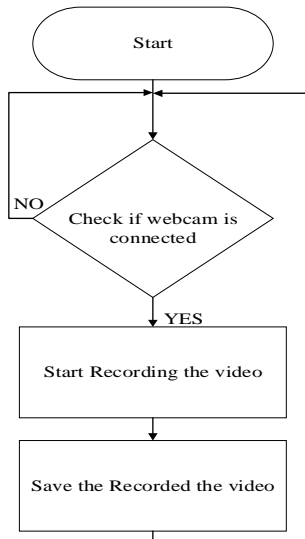

Fig. 6 Flow chart of software program

d) *Saving of the video:* The program is capable to recording the live video of the scene when the intruder is in its detection range. The captured video is saved in the media file format in the computer. The files are saved with the file name of date and time of the detection. This avoids the files replacement and it is easy for a person to find the time of an intruder in the area. The videos are recorded only when there are intruder otherwise the PIR sensor remains idle; the webcam and lamp circuit remains incomplete. This saves memory space of the recording system and power consumption.

III. SYSTEM TESTING AND ANALYSIS

A. System Testing

The system prototype was tested in the lab, where the normal temperature ranges from 300 K to 308 K. The software was kept running in the laptop and an intruder was let to come into the detection range of the PIR sensor.

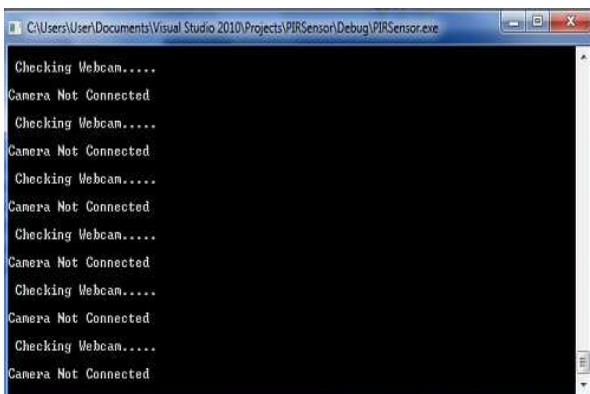

Fig. 7 Program running when there is no intruder

Fig. 8 shows the program checking if the webcam is connected i.e. if it is turned ON. It keeps checking until it detects the webcam. A friend was made to enter the detection range of the PIR sensor. The lamp and the webcam got turned ON since PIR sensor got activated and generated an output which actually actuated lamp and webcam as shown in Fig. 9.



Fig. 8 When intruder was in the detection range of PIR sensor, lamp and webcam got turned ON

The program detects the webcam and starts to record the video captured by the webcam as shown in the Fig. 10.

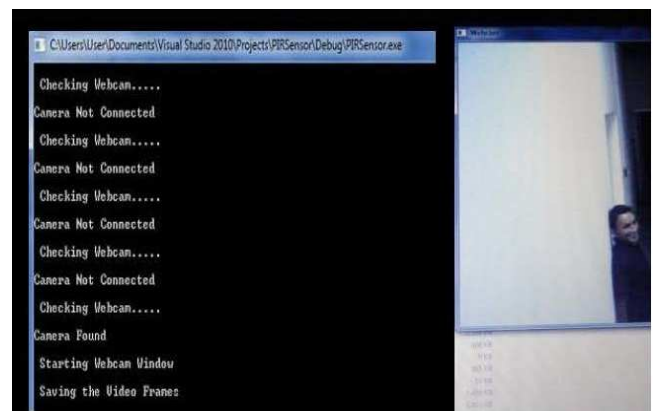

Fig. 9 The program capturing the live video

Once the intruder left the detection range of PIR sensor, the lamp and webcam got turned OFF. The PIR sensor goes to idle mode. The software saved the video captured and it started to again check if the webcam is connected or not. When the intruder comes in the detection range of PIR sensor, the process of recording and saving the video will repeat.

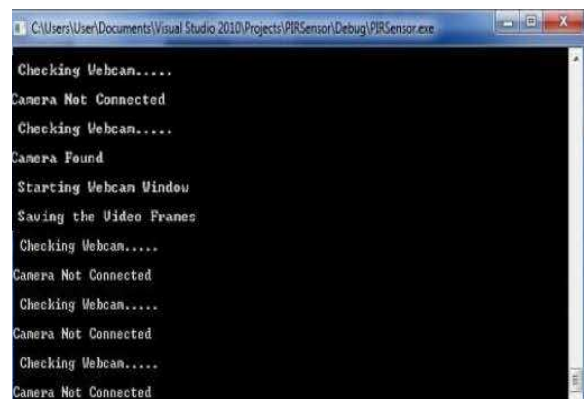

Fig. 10 The program checking if the webcam is connected

B. Analysis

The proposed system provides saving in memory space of the system by recording video only when the webcam is turned ON and low power consumption.

It was observed that the lamp and the webcam gets turned ON as soon as the power is given to the circuit without even having intruder in the detection range of the sensor. This

actually happens because the PIR sensor requires an initial stabilization period of 10 to 60 seconds in order to function properly. During this time, the sensor gets familiar with the surrounding environment, and any motion in its field of view should be avoided and this was taken care when we made system to run. After 15 seconds, the lamp and webcam gets turned OFF as there is no intruder in the detection range of the system. Also, the sensor took approximately 15 seconds to get to idle state after the intruder has left the scene or the range of the detection. Consequently, this keeps the lamp and the webcam ON for that duration; the video captured by the webcam during this period of 15seconds will be recorded and it will be saved in the memory of the system. This results in wastage of memory location used by the video captured by webcam in those 15 seconds. This problem could be solved by using PIR sensor of very good sensitivity.

After the PIR sensor has detected the intruder and turns ON the webcam, there was time delay for the program to detect that the webcam is ON and to start recording the video. This is because the program needs to check the computer's hardware for the availability of the webcam and if it is connected to the system; the computer in turn has to load the drivers when the webcam gets connected. This causes the delay in starting the recording which has been observed to be between 5 to 10 seconds.

IV. FUTURE WORKS

In this PIR Sensor Based Security System, we have used low power, low cost PIR sensor that are easy to interface with other components. By using this system we were able to reduce the power consumed and memory space of the system.

Currently, we have used only one webcam in our project which could only capture the area facing to it. The system may not work if the intruders enter from other side. The software developed for the recording of the video captured by the webcam is experimented only with a webcam connected to the system also there was some delay in recording video captured by the webcam.

Considering all above points, followings are our future works set to improve the system:

- Work on to reduce the delay time in recording the video captured by webcam.
- Use more than one webcam and integrating these webcams with the system.
- Work on the software to record videos from many webcams installed.

V. CONCLUSION

In this paper, a PIR sensor based security system is proposed. Despite some delays taking place in recording the video captured, it was observed that the proposed system can save the memory space of the recording system as it starts recording when the webcam is turned ON. Also the power consumed by the lighting system at night can be reduced as the lighting system only gets turned ON only when PIR sensor gets activated. Both webcam and lighting system gets ON only when there is an intruder in the detection range of the PIR sensor.

ACKNOWLEDGMENT

We would like to thank College of Science and Technology, Royal University of Bhutan for facilitating and supporting us with the requirements to fulfil the project.

REFERENCES

- [1] Zamshed Iqbal Chowdhury, Haider Masudul Intiaz, Moinul Muhammad Azam, Aktar Mst. Rumana Sumi, and Nafisa Shahera Nur, "Design and Implementation of Pyroelectric Infrared Sensor Based Security System Using Microcontroller," in *Proceeding of the 2011 IEEE Students' Technology Symposium 14-16 January, 2011*, IIT Kharagpur, 2013.
- [2] Piero Zappi, Elisabetta Farella, and Luca Benini, "Tracking motion direction and distance with Pyroelectric InfraRed Sensors," *IEEE Sensor Journal Class Files*, 2008.
- [3] Herbert L. Berman and Los Altos Hills, "Infrared Intrusion Detector System," 3,73,718, Nov 21, 1972.
- [4] L. Herbert, Berman, Altos Hills Los, and Calif, "Infrared Intrusion Detector System," 3,703,718, Nov. 21, 1972.
- [5] S. Yuvaraj Prof. and Ramesh S., "Improved Response Time on Safety Mechansim Based on PIR sensor," *International Journal of Emerging Technology and Advanced Engineering*, vol. 2, no. 4, April 2012.
- [6] Anonymus (2007, March 13), "The Electromagnetic Spectrum" [online] <http://science.hq.nasa.gov/kids/imagers/ems/infrared.html>
- [7] David W. Crick and West Molesey, "Passive Infrared intruder Detector System," 4,242,6690, December 30, 1980.
- [8] Anonymus. (2013, April) OpenCV Documentation. [Online]. <http://docs.opencv.org/index.html>
- [9] FunctionX Inc. (2010) FunctionX Tutorials. [Online]. <http://www.functionx.com/cpp4mfc/Lesson01.htm>